

- I** AUTOMAZIONE ELETTROMECCANICA INTERRATA PER CANCELLI A BATTENTE
- GB** ELECTROMECHANIC AUTOMATIONS FOR SWING GATES
- F** AUTOMATISME ELECTROMECHANIQUE ENTERRÉ POUR PORTAILS A VANTAUX
- D** ELEKTROMECHANISCHER ANTRIEB FÜR FLÜGELGITTERTORE
- E** AUTOMATISMO ELECTROMECHANICO SOTERRADO PARA CANCELAS BATIENTES
- P** AUTOMATIZAÇÃO ELECTROMECHANICA SUBTERRNEA PARA PORTÕES COM BATENTE

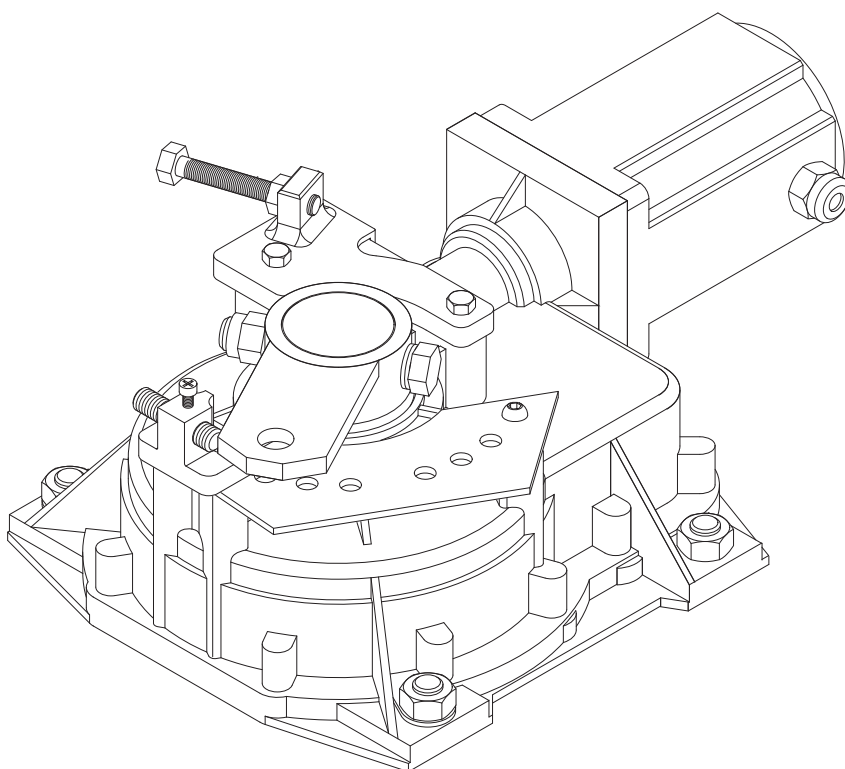

ELI-250



ISTRUZIONI D'USO E DI INSTALLAZIONE
INSTALLATION AND USER'S MANUAL
INSTRUCTIONS D'UTILISATION ET D'INSTALLATION
INSTALLATIONS UND GEBRAUCHSANLEITUNG
INSTRUCCIONES DE USO Y DE INSTALACION
INSTRUÇÕES DE USO E DE INSTALAÇÃO



**AZIENDA CON SISTEMA
 DI GESTIONE INTEGRATO
 CERTIFICATO DA DNV
 = UNI EN ISO 9001:2000 =
 UNI EN ISO 14001:1996**

Via Lago di Vico, 44
 36015 Schio (VI)
 Tel.naz. 0445 696511
 Tel.int. +39 0445 696533
 Fax 0445 696522
 Internet: www.bft.it
 E-mail: sales@bft.it

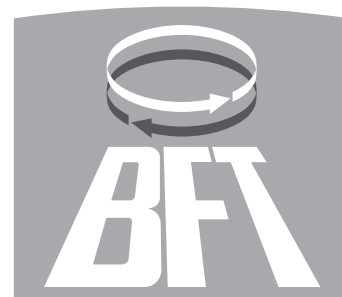

**DICHIARAZIONE DI CONFORMITÀ / DECLARATION OF CONFORMITY / DÉCLARATION DE CONFORMITÉ
KONFORMITÄTSERKLÄRUNG / DECLARACION DE CONFORMIDAD / DECLARAÇÃO DE CONFORMIDADE**
(Dir. 98/37/EEC allegato / annex / on annexe / anlage / adjunto / ficheiro IIB)

Fabbricante / Manufacturer / Fabricant / Hersteller / Fabricante / Fabricante:

BFT S.p.a.

Indirizzo / Address / Adresse / Adresse / Dirección / Endereço:

Via Lago di Vico 44
36015 - Schio
VICENZA - ITALY

- Dichiaro sotto la propria responsabilità che il prodotto: / Declares under its own responsibility that the following product:
/Déclare sous sa propre responsabilité que le produit: / Erklärt auf eigene Verantwortung, daß das Produkt: /Declara, bajo su propia responsabilidad, que el producto: / Declara, sob a sua responsabilidade, que o produto:

Motoriduttore per cancelli a battente mod. / Gearmotor for swing gates mod. / Motoréducteur pour portails battants mod. /
Getriebemotor für Drehtore Modell / Motorreductor para cancelas con batiente mod. / Motoredutor para portões de batente mod.

ELI 250, ELI 250-V

- È costruito per essere incorporato in un macchinario che verrà identificato come macchina ai sensi della DIRETTIVA MACCHINE. / Has been produced to be incorporated into a machinery, which will be identified as a machine according to the MACHINERY DIRECTIVE. / A été construit pour l'incorporation successive dans un équipement qui sera identifié comme machine conformément à la DIRECTIVE MACHINES. / Dafür konstruiert wurde, in ein Gerät eingebaut zu werden, das als Maschine im Sinne der MASCHINEN-DIREKTIVE identifiziert wird. / Ha sido construido para ser incorporado en una maquinaria, que se identificará como máquina de conformidad con la DIRECTIVA MAQUINAS. / Foi construído para ser incorporado numa maquinaria, que será identificada como máquina em conformidade com a DIRECTIVA MÁQUINAS
- È conforme ai requisiti essenziali di sicurezza delle Direttive: / It complies with the main safety requirements of the following Directives: / Est conforme aux exigences essentielles de sécurité des Directives: / Es entspricht den grundlegenden Sicherheitsbedingungen der Direktiven: / Es conforme a los requisitos esenciales de seguridad de las Directivas: / Está conforme aos requisitos essenciais de segurança das Directivas:

BASSA TENSIONE / LOW VOLTAGE / BASSE TENSION / NIEDERSPANNUNG / BAJA TENSION / BAIXA TENSÃO
73/23/CEE, 93/68/CEE (EN60335-1 ('94)) (e modifiche successive / and subsequent amendments / et modifications successives /
und ihren nachfolgende Änderungen / e modificações sucessivas / y modificaciones sucesivas).

COMPATIBILITÀ ELETTROMAGNETICA / ELECTROMAGNETIC COMPATIBILITY / COMPATIBILITÉ ÉLECTROMAGNÉTIQUE /
ELEKTROMAGNETISCHE KOMPATIBILITÄT / COMPATIBILIDAD ELECTROMAGNETICA / COMPATIBILIDADE
ELECTROMAGNÉTICA 89/336/CEE, 91/263/CEE, 92/31/CEE, 93/68/CEE (EN61000-6-1, EN61000-6-2, EN61000-6-3,
EN61000-6-4, EN55014-1, EN55014-2) (e modifiche successive / and subsequent amendments / et modifications successives /
und ihren nachfolgende Änderungen / e modificações sucessivas / y modificaciones sucesivas).

- Si dichiara inoltre che è vietata la messa in servizio del prodotto, prima che la macchina in cui sarà incorporato, sia stata dichiarata conforme alle disposizioni della DIRETTIVA MACCHINE. / We also declare that it is forbidden to start the product before the machinery into which it will be incorporated is declared in compliance with the prescriptions of the MACHINERY DIRECTIVE. / Nous déclarons en outre que la mise en service du produit est interdite, avant que la machine où il sera incorporé n'ait été déclarée conforme aux dispositions de la DIRECTIVE MACHINES. / Es wird außerdem erklärt, daß die Inbetriebnahme des Produkts verboten ist, solange die Maschine, in die es eingebaut wird, nicht als mit den Vorschriften der MASCHINEN-DIREKTIVE konform erklärt wurde. / Se declara, además, que está prohibido instalar el producto antes de que la máquina en la que se incorporará haya sido declarada conforme a las disposiciones de la DIRECTIVA MAQUINAS / Declaramos, além disso, que é proibido instalar o produto, antes que a máquina em que será incorporada, tenha sido declarada conforme às disposições da DIRECTIVA MÁQUINAS

SCHIO, 20/04/2004

Il Rappresentante Legale / The legal Representative
Le Représentant Légal / Der gesetzliche Vertreter
El Representante Legal / O Representante legal



(GIANCARLO BONOLLO)

Thank you for buying this product, our company is sure that you will be more than satisfied with the performance of the product. This product is supplied with a "Warnings" leaflet and an "Instruction manual". These should both be read carefully as they provide important information about safety, installation, operation and maintenance. This product complies with recognised technical standards and safety regulations. We declare that this product is in conformity with the following European Directives: 89/336/EEC, 73/23/EEC, 98/37/EEC, 99/05/EEC (and subsequent amendments). **WARNINGS: Any assistance required on automation components must be carried out by a qualified technician (installer).**

1) GENERAL OUTLINE

The **ELI-250** electromechanical actuator is the ideal solution for underground hinge-pivot installation. The actuator consists of a perfectly sealed single-block reduction gear. The under hinge-pivot position maintains the aesthetic appearance of the gate and practically hides the automation system. Once the bearing case is installed, the gate can be operated even without fitting the actuator which can be inserted later. When maintenance is required, this type of case allows the actuator to be taken out without removing the gate leaf. The **ELI-250** actuator can be fitted to any type of swing gate which meets the values shown in the "Technical Specifications" table. The pushing force is set on the control unit (see specific manual). The end-of-stroke operation is adjusted by mechanical stops located inside the foundation case. **CAUTION! The actuator mod. ELI-250 is not provided with mechanical torque adjustment. It is compulsory to use a control board of the same manufacturer, according to the basic safety requirements of directives 89/336/EEC, 73/23/EEC, 98/37/EEC, 99/05/EEC and provided with adequate electric torque adjustment.**

2) EMERGENCY MANOEUVRE

Emergency release is obtained by using the key provided, on the release unit which is located under the gate, on the protruding section of the lever-pivot. To release, insert the key in the release triangle and turn it by about 90° in the direction shown by the open-padlock symbol (fig.1). If the leaf is equipped with an electric lock, release the electric lock as well. To open/close the gate, push it manually. To restore motor-driven operation, reposition the gate by aligning it with the lever bearing the lock unit, and turn the key in the direction shown by the closed-padlock symbol (fig.1) checking that engagement is correctly restored. Keep the leaf release key (and that of the electric lock, if any) in a place which is known to the users.

3) AUTOMATION OPERATION

Since the automation system can be remotely controlled by means of a radio control device or a Start button, and therefore out of sight, all safety devices must be frequently checked in order to ensure their perfect efficiency. In the event of any anomalous operation, request immediate assistance from qualified personnel. Children must be kept at a safe distance from the automation operation area.

4) SCRAPPING

Materials must be disposed of in conformity with the current regulations.

In case of scrapping, the automation devices do not entail any particular risks or danger. In case of recovered materials, these should be sorted out by type (electrical components, copper, aluminium, plastic etc.).

5) DISMANTLING

When the automation system is disassembled to be reassembled on another site, proceed as follows:

- Disconnect the power supply and the entire electrical installation.
- Remove the gearmotor from its fixing base.
- Disassemble the control panel, if separate, and all installation components.
- In the case where some of the components cannot be removed or are damaged, they must be replaced.

6) MALFUNCTION: CAUSES AND REMEDIES

When any operational malfunction is found, and not resolved, disconnect the mains power supply and request the assistance of a qualified technician (installer).

When automation is out of order, activate the manual release to allow the opening and closing operations to be carried out manually.

During this period of time, keep the lock in the closed position by means of a chain and padlock.

Fig. 1

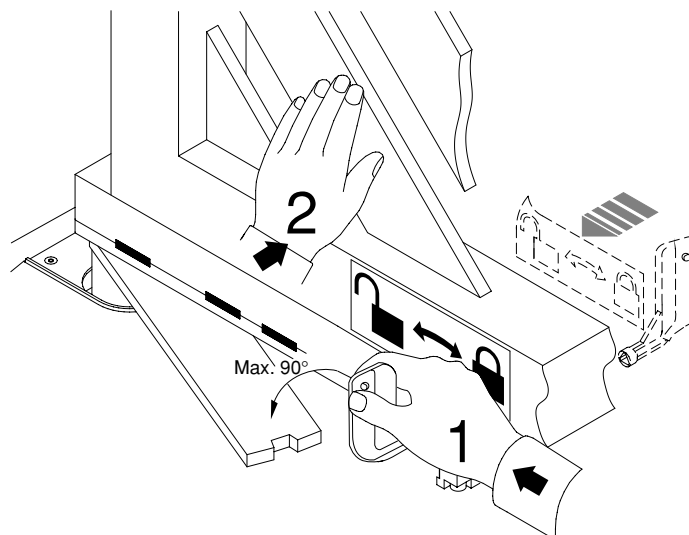

Thank you for buying this product, our company is sure that you will be more than satisfied with the performance of the product. This product is supplied with a "Warnings" leaflet and an "Instruction manual". These should both be read carefully as they provide important information about safety, installation, operation and maintenance. This product complies with recognised technical standards and safety regulations. We declare that this product is in conformity with the following European Directives: 89/336/EEC, 73/23/EEC, 98/37/EEC, 99/05/EEC (and subsequent amendments).

WARNINGS: Any assistance required on automation components must be carried out by a qualified technician (installer).

1) GENERAL OUTLINE

The **ELI-250** electromechanical actuator is the ideal solution for underground hinge-pivot installation. The actuator consists of a perfectly sealed single-block reduction gear. The under hinge-pivot position maintains the aesthetic appearance of the gate and practically hides the automation system.

Once the bearing case is installed, the gate can be operated even without fitting the actuator which can be inserted later. When maintenance is required, this type of case allows the actuator to be taken out without removing the gate leaf. The **ELI-250** actuator can be fitted to any type of swing gate which meets the values shown in the "Technical Specifications" table. The pushing force is set on the control unit (see specific manual).

The end-of-stroke operation is adjusted by mechanical stops located inside the foundation case.

CAUTION! The actuator mod. ELI-250 is not provided with mechanical torque adjustment. It is compulsory to use a control board of the same manufacturer, according to the basic safety requirements of directives 89/336/EEC, 73/23/EEC, 98/37/EEC, 99/05/EEC and provided with adequate electric torque adjustment.

2) GENERAL SAFETY

WARNING! An incorrect installation or improper use of the product can cause damage to persons, animals or things.

- The "Warnings" leaflet and "Instruction booklet" supplied with this product should be read carefully as they provide important information about safety, installation, use and maintenance.
- Scrap packing materials (plastic, cardboard, polystyrene etc) according to the provisions set out by current standards. Keep nylon or polystyrene bags out of children's reach.
- Keep the instructions together with the technical brochure for future reference.
- This product was exclusively designed and manufactured for the use specified in the present documentation. Any other use not specified in this documentation could damage the product and be dangerous.
- The Company declines all responsibility for any consequences resulting from improper use of the product, or use which is different from that expected and specified in the present documentation.
- Do not install the product in explosive atmosphere.
- The construction components of this product must comply with the following European Directives: 89/336/EEC, 73/23/EEC, 98/37/EEC, 99/05/EEC and subsequent amendments. As for all non-EEC countries, the above-mentioned standards as well as the current national standards should be respected in order to achieve a good safety level.
- The Company declines all responsibility for any consequences resulting from failure to observe Good Technical Practice when constructing closing structures (door, gates etc.), as well as from any deformation which might occur during use.
- The installation must comply with the provisions set out by the following European Directives: 89/336/EEC, 73/23/EEC, 98/37/EEC, 99/05/EEC and subsequent amendments.
- Disconnect the electrical power supply before carrying out any work on the installation. Also disconnect any buffer batteries, if fitted.
- Fit an omnipolar or magnetothermal switch on the mains power supply, having a contact opening distance equal to or greater than 3,5 mm.
- Check that a differential switch with a 0.03A threshold is fitted just before the power supply mains.
- Check that earthing is carried out correctly: connect all metal parts for closure (doors, gates etc.) and all system components provided with an earth terminal.
- Fit all the safety devices (photocells, electric edges etc.) which are needed to protect the area from any danger caused by squashing, conveying and shearing, according to and in compliance with the applicable directives and technical standards.
- Position at least one luminous signal indication device (blinker) where it can be easily seen, and fix a Warning sign to the structure.

- The Company declines all responsibility with respect to the automation safety and correct operation when other manufacturers' components are used.
- Only use original parts for any maintenance or repair operation.
- Do not modify the automation components, unless explicitly authorised by the company.
- Instruct the product user about the control systems provided and the manual opening operation in case of emergency.
- Do not allow persons or children to remain in the automation operation area.
- Keep radio control or other control devices out of children's reach, in order to avoid unintentional automation activation.
- The user must avoid any attempt to carry out work or repair on the automation system, and always request the assistance of qualified personnel.
- Anything which is not expressly provided for in the present instructions, is not allowed.

3) MAIN AUTOMATION PARTS

Sealed mechanical actuator (fig.1) including:

- Single-phase 2-pole motor protected by thermal circuit-breaker.
- Double worm-screw reduction gear with output gear in special aluminium alloy.
- Output lever and mechanical stops.
- Bearing foundation case (ready for automation).
- Series of levers for gate movement.
- Release unit with key.

CAUTION! The actuator can be fitted either on the left or on the right, which are conventionally defined by looking at the gate from the inside (opening direction).

4) TECHNICAL SPECIFICATIONS

Single-phase power supply	230Vac ±10% 50Hz (*)
Motor revolutions	1400min ⁻¹
Output shaft revolutions.....	ELI250 0.95min ⁻¹ - ELI250V 1.9min ⁻¹
Absorbed power	280W
Capacitor	10µF
Absorbed current	1,4A
Opening time 120°	ELI250 28s - ELI250V 14s
Max torque.....	ELI250 380Nm - ELI250V 240Nm
Max leaf length/weight.....	ELI250 2.5m/3000N (~300kg) ELI250 3.5m/2500N (~250kg) ELI250V 2m/1500n (~150kg)
Max. leaf opening	120°
Blocking function	Irreversible gearmotor; electric lock necessary for leaves longer than 2,5m
Impact reaction	Electronic clutch (with control panel)
Manual manoeuvre.....	Release key
Max. no. manoeuvres in 24 hours.....	100
Thermal protection	130°C self-resetting
Environmental conditions	from -20°C to +50°C
Lubrication	Permanent grease
Degree of protection	IP67 AM
Actuator weight.....	100N (~ 10kg)
Overall dimensions	See fig.3

(*) Special voltages on request.

5) ACTUATOR INSTALLATION

5.1) Preliminary checks

Check that:

- The upper hinge is in good condition and possibly adjustable.
- A hole can be dug for burying the case under the hinge.
- The "FA" stop plates of the leaves are installed (fig.8).
- Repair or replace the faulty or worn parts of the structures to be subjected to movement.

An exploded view of the installation is shown in fig.1.

The automation reliability and safety are directly influenced by the state of the gate structure.

5.2) The main automation components are (Fig.2):

- Type-approved adequately rated omnipolar circuit breaker with at least 3,5 mm contact opening, provided with protection against overloads and short circuits, suitable for cutting out automation from the mains. Place, if not already installed, a type-approved differential switch with a 0.03A threshold just before the automation system.

Qr) Control panel and built-in receiver.

- S) Key selector.
- AL) Blinker with tuned antenna.
- M) Actuator.
- E) Electric lock (compulsory for leaves longer than 2,5m).
- Fte) Pair of external photocells (transmitter section).
- Fre) Pair of external photocells (receiver section).
- Fti) Pair of internal photocells with CF posts (transmitter section).
- Fri) Pair of internal photocells with CF posts (receiver section).
- T) 1-2-4 channel transmitter.
- RG58) Cable for antenna.
- D) Connector block.

5.3) Electrical installation set-up

Lay out the electrical installation as shown in fig. 2, with reference to the CEI 64-8 and IEC 364 provisions, complying with the HD 384 and other national standards in force for electrical installation. The mains power supply connections must be kept totally separate from the service connections (photocells, electric edges, control devices etc.).

WARNING! For connection to the mains, use a multipolar cable with a minimum of 3x1.5mm² cross section and complying with the previously mentioned regulations. For example, if the cable is outside (in the open), it has to be at least equal to H07RN-F, but if it is on the inside (or outside but placed in a plastic cable channel) it has to be or at least equal to H05VV-F with section 3x1.5mm².

Connect the control and safety devices in compliance with the previously mentioned electrical installation standards. Fig. 2 shows the number of connections and the cross section for cables having a length of approximately 100 metres; in case of longer cables, calculate the cross section for the actual automation load.

Warning! For actuator wiring and accessory connection, refer to the relevant instruction manuals. The control panels and accessories must be suitable for use and conform to current standards.

5.4) Foundation case cementing

The foundation case must be cemented under the hinge pivot, taking into consideration that the actuator bearing shaft must be perfectly aligned with the leaf rotation axis. If the gate has fixed hinges, remove the gate and the lower hinge. If the leaf is sufficiently separated from the ground and cannot be removed, proceed to supporting it by means of a shim placed between the ground and the leaf during installation. If the gate has adjustable hinges, remove the lower one, slacken the upper hinge and move the leaf to the side. If the gate has been recently installed, fit an upper adjustable hinge. Dig a foundation hole having the dimensions specified in fig.4. Lay an drain pipe (fig. 4) for rainwater in order to prevent it from being collected inside the foundation case. Lay a raceway for the power supply cable as far as connector block "D". Lay a solid foundation (fig.3) at the bottom, where to bury the foundation box. To obtain good squareness between cases and leaves, set out their alignment using a stretched rope between the 2 bearing pivots, and aligning the 2 reference points "C" with each other (see fig.12).

Let the cement harden for the time needed.

6) GATE LEAF FITTING

- Abundantly grease the pivot in the foundation case.
 - Position the lever assembly by inserting pipe "A" into the pivot of the foundation case, as in fig.9. If the height of the assembled levers is not sufficient, insert shim "S" between the assembled lever unit and the gate leaf, as in fig.5.
 - Place the gate leaves in the closing and in the closed position against the centre stop plate.
 - Perfectly align the assembled lever unit to the hinge.
 - If a shim is used, weld it to the leaf first and then weld the lever unit to the shim.
 - Check the leaf operation.
 - If the gearmotor is not to be installed, fit the foundation case cover and fix with suitable screws.
- At this stage, the gate opens and closes manually. All that remains to be done is to position the gearmotor.

7) GEARMOTOR FITTING

Remove the nuts from the bottom of the case using a CH19 socket wrench. The gearmotor is to be fixed to the foundation case in the position shown in fig.6 and 8, using the 4 nuts which were previously removed.

- Tighten screws "VR" (fig.7) and respective locknuts to the end-of-stroke brackets and identify the left or right fastening position (fig.8).
- Fix the mechanical end-of-stroke brackets using the M8 screws provided (fig.7).

- Fit the motor-pivot connecting lever components following the correct sequence given in fig.9.

In the case where the position of the levers interferes with the assembly of the components, supply the motors with current (by means of the control unit) until the levers reach the required position.

- **Fig.9: insert the greaser (C) into the threaded hole of the lever (A). The type of grease recommended is: Rocol FOODLUBE MULTIPASTE.**
- Grease the hub where pipe "A" must be inserted.
- Check the opening and closing operations.
- Attach to the leaf the internal and external release labels observing the direction and position indicated in fig.14. The open-padlock symbol must always be directed towards the leaf rotation axis.
- Connection of the gearmotor cable must be carried out in a junction box positioned outside the foundation case without cutting the cable supplied as standard (Fig.2-4-5 Ref.D).

8) END-OF-STROKE ADJUSTMENT

If no ground stop plates "FA" are fitted, adjust the internal stops using the screws "VRC-VRO" (fig.10-11) until the leaf stops at the required point.

The mechanical stop for the opening and closing operations can be adjusted by means of the appropriate screws "VRC-VRO".

- On **CLOSING** (fig.10): The end-of-stroke adjusting screw "VRC" should come into contact with lever "L" after the leaf has reached the centre stop plate "FA" (fig.8). This guarantees that the leaf rests against the centre stop plate "FA" which, if provided with a rubber cap, avoids banging noises. In the case where, during the adjustment of the end-of-stroke stop "VRC", measurement "Z" (fig.8) becomes greater than 18±20 mm, the stop should be turned as in fig.13a.
- On **OPENING** (fig.11): The end-of-stroke adjusting screw "VRO" must come into contact with lever "L" after the leaf has reached the centre stop plate "FA" (fig.8).
- After completing the adjustment, tighten the locknut on the end-of-stroke adjustment screws "VRO" together with the screw tightening the end-of-stroke dowel "VRC".
- Repeat the same procedure for the second actuator.
- If the foundation case is not orthogonal to the leaf, a 10% adjustment can be carried out both in clockwise and anticlockwise directions, by positioning the support bracket and the stop plate as shown in fig. 13b.

9) MOTOR TORQUE SETTING

CAUTION! When using the **ARIES** mod. control unit with the torque set to "F4" (maximum torque), it is compulsory to fit the ground stop plates "FA" both on opening and closing.

The motor torque (antisquash) setting takes place in the control unit. See the control unit instruction manual. The wiring diagram of the motor is included in the instructions for use for the relative control unit. This setting must be calibrated according to the minimum force needed to carry out the complete opening and closing strokes, and always within the limits provided for by current standards.

WARNING! Check that the impact force value measured at the points established by the EN 12445 standard is lower than that specified in the EN 12453 standard.

CAUTION! Excessive torque setting can jeopardise antisquash safety. On the contrary, insufficient torque setting may not guarantee a correct opening or closing stroke.

10) EMERGENCY MANOEUVRE

Emergency release is obtained by using the key provided, on the release unit which is located under the gate, on the protruding section of the lever-pivot. To release, insert the key in the release triangle and turn it by about 90° in the direction shown by the open-padlock symbol (fig.14). If the leaf is equipped with an electric lock, release the electric lock as well.

To open/close the gate, push it manually. To restore motor-driven operation, reposition the gate by aligning it with the lever bearing the lock unit, and turn the key in the direction shown by the closed-padlock symbol (fig.14) checking that engagement is correctly restored. Keep the leaf release key (and that of the electric lock, if any) in a place which is known to the users.

11) AUTOMATION CHECK

Before making the automation fully operational, carefully carry out the following procedure:

- Check that all components are tightly fixed.
- Check the correct operation of all safety devices (photocells, electric edges etc.).
- Check the emergency manoeuvre command.
- Check the opening and closing operations with the control devices provided.
- Check the standard or customised electronic function logic.

12) AUTOMATION OPERATION

Since the automation system can be remotely controlled by means of a radio control device or a Start button, and therefore out of sight, all safety devices must be frequently checked in order to ensure their perfect efficiency. In the event of any anomalous operation, request immediate assistance from qualified personnel.

Children must be kept at a safe distance from the automation operation area.

13) CONTROL

The automation system allows motor-driven gate opening and closing operations to be carried out. Various types of control are provided (manual, radio control, magnetic card access control etc.) depending on the installation requirements and characteristics. See the specific instructions for the various control systems. All automation system users must be instructed on automation control and operation.

14) MAINTENANCE

Before carrying out any maintenance to the installation, disconnect the mains power supply.

- Periodically check that hinge-pivots are in good condition and properly greased.
- Grease the pin on the foundation case every two years, using the appropriate greaser (C) located on the lever (A) as shown in Fig.9.
The type of grease recommended is: [ROCOL FOODLUBE MULTIPASTE](#).
- Occasionally clean the photocell optical components.
- Have a qualified technician (installer) check the correct setting of the electric clutch.
- If the power supply cable is damaged, it must be replaced by the manufacturer or its technical assistance service, or else by a suitably qualified person, in order to prevent any risk.
- When any operational malfunction is found, and not resolved, disconnect the mains power supply and request the assistance of a qualified technician (installer). When automation is out of order, activate the manual release to allow the opening and closing operations to be carried out manually.

15) NOISE

The aerial noise produced by the gearmotor under normal operating conditions is constant and does not exceed 70dB(A).

16) SCRAPPING

Materials must be disposed of in conformity with the current regulations. In case of scrapping, the automation devices do not entail any particular risks or danger. In case of recovered materials, these should be sorted out by type (electrical components, copper, aluminium, plastic etc.).

17) DISMANTLING

When the automation system is disassembled to be reassembled on another site, proceed as follows:

- Disconnect the power supply and the entire electrical installation.
- Remove the gearmotor from its fixing base.
- Disassemble the control panel, if separate, and all installation components.
- In the case where some of the components cannot be removed or are damaged, they must be replaced.

18) MALFUNCTION: CAUSES AND REMEDIES

When any operational malfunction is found, and not resolved, disconnect the mains power supply and request the assistance of a qualified technician (installer).

When automation is out of order, activate the manual release to allow the opening and closing operations to be carried out manually.

During this period of time, keep the lock in the closed position by means of a chain and padlock.

18.1) The gate does not open. The motor does not turn.

- a) Check that the photocells or electric edges are not dirty, or impregnated, or misaligned. Proceed accordingly.
- b) Check that the electronic appliance is correctly supplied. Check the integrity of the fuses.
- c) Check that the individual devices operate correctly.
- d) If the control unit does not work, it must be replaced.
In the case where the above-mentioned checks give no results, contact an authorised customer service centre.

If the supply cable is damaged, it must be replaced by the manufacturer, by its technical service center or, in any case, by a qualified technician so as to avoid any risk.

18.2) The gate does not open. The actuator vibrates but there is no movement.

- a) Check that the capacitor is connected to the motor running terminals.
- b) Check that the common wire of the motor (light blue) is correctly connected.
- c) Disconnect and reconnect the mains power supply. The first Start command must open. Should the actuator move to the closing function, reverse the respective running connections.
- d) Manually help the leaf opening operation. If the leaf opens, check whether there are any mechanical problems. In the case where the above-mentioned checks give no results, increase the torque in the control unit and, if necessary, contact a qualified technician.

WARNINGS. Correct operation of the actuator is only guaranteed when the data specified in this manual are respected.

The company cannot be held responsible for any damage caused by failure to observe the installation standards and directives specified in the present manual.

The descriptions and illustrations contained in the present manual are not binding. The Company reserves the right to make any alterations deemed appropriate for the technical, manufacturing and commercial improvement of the product, while leaving the essential product features unchanged, at any time and without undertaking to update the present publication.

Fig. 3

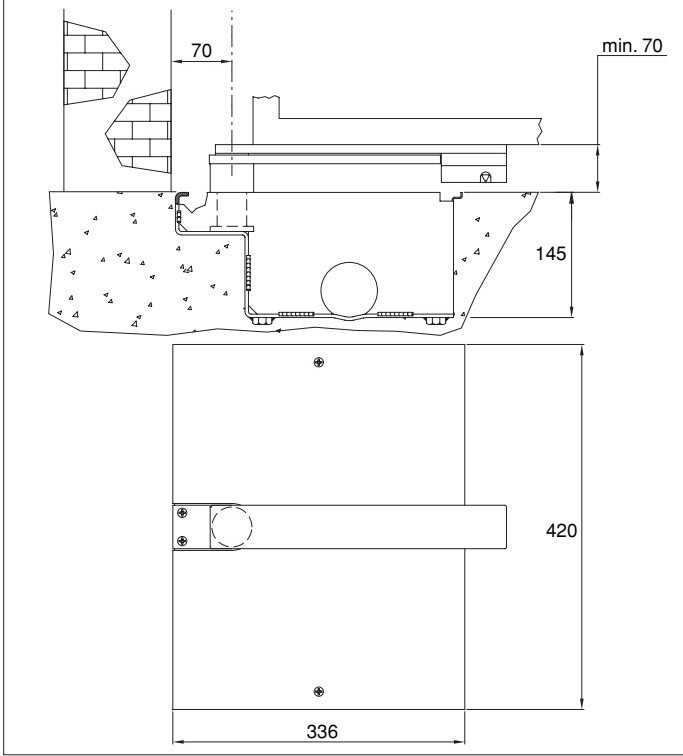

Fig. 4

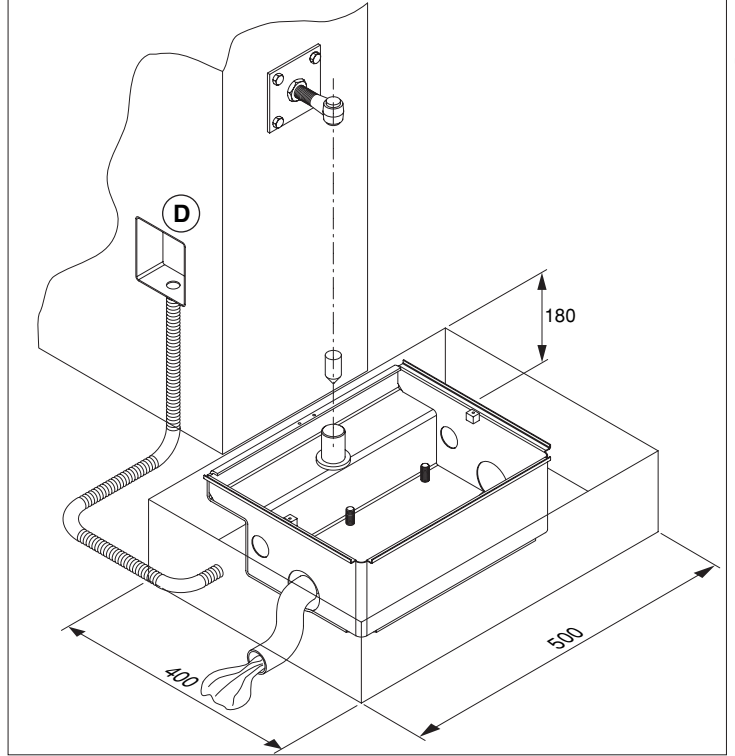

Fig. 5

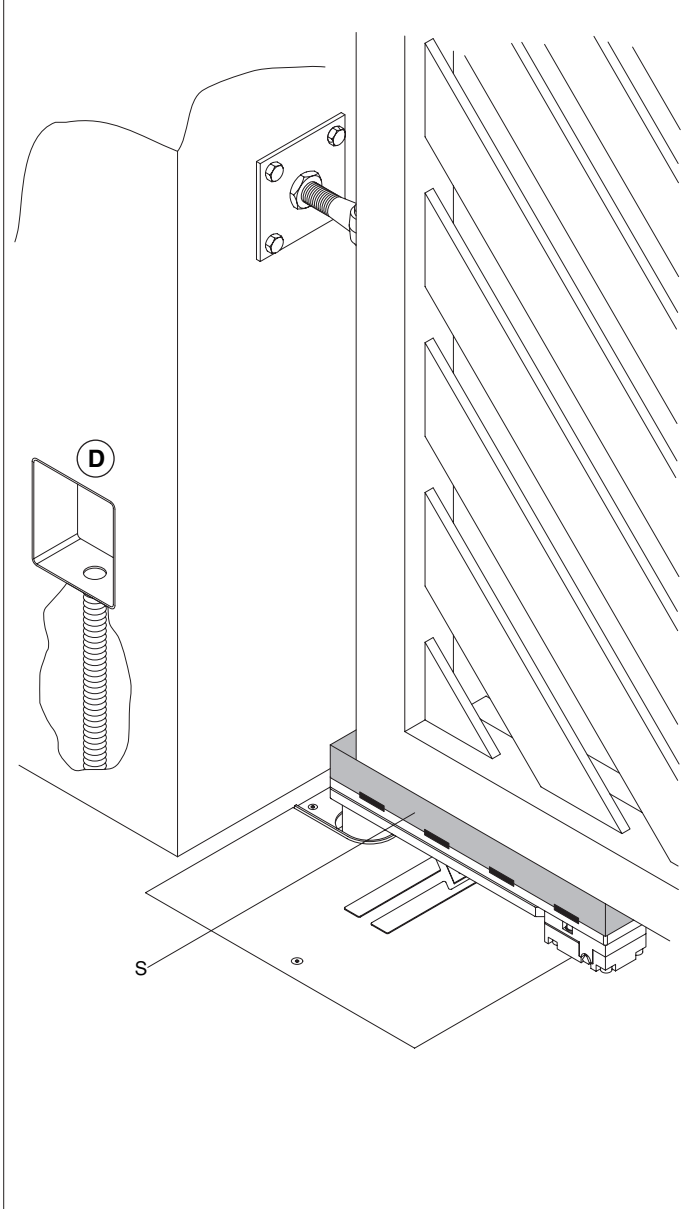

Fig. 6

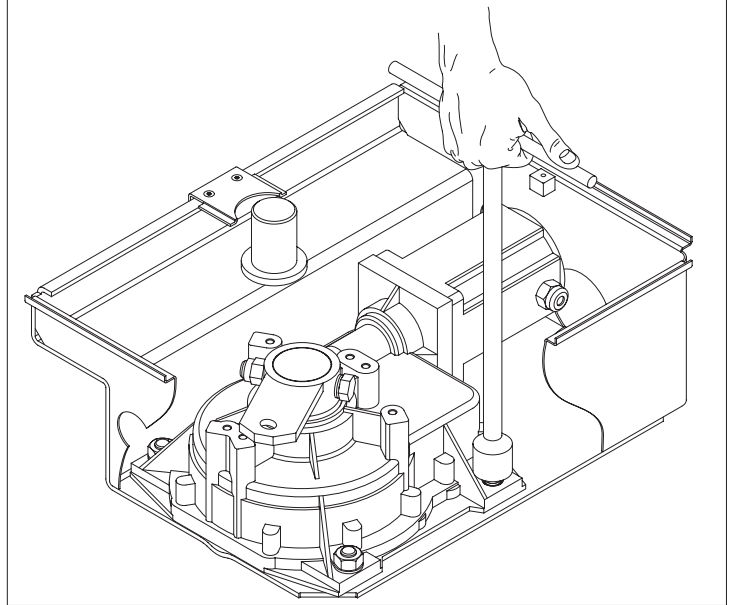

Fig. 7

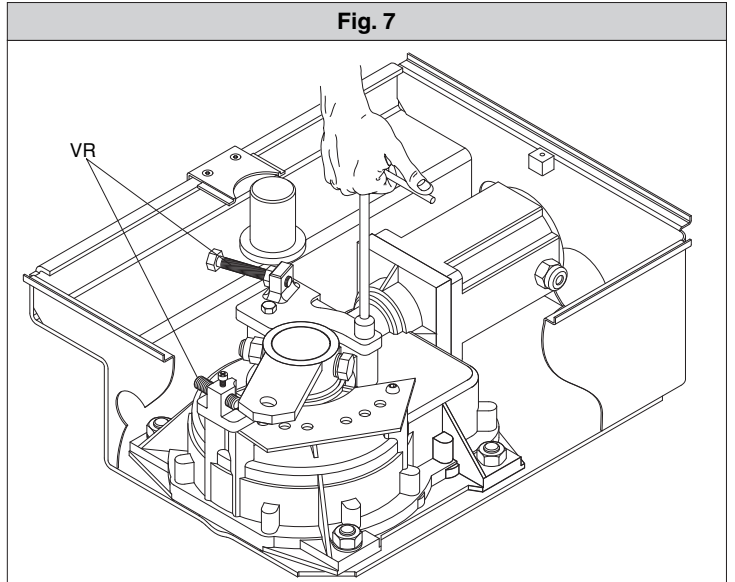

Fig. 8

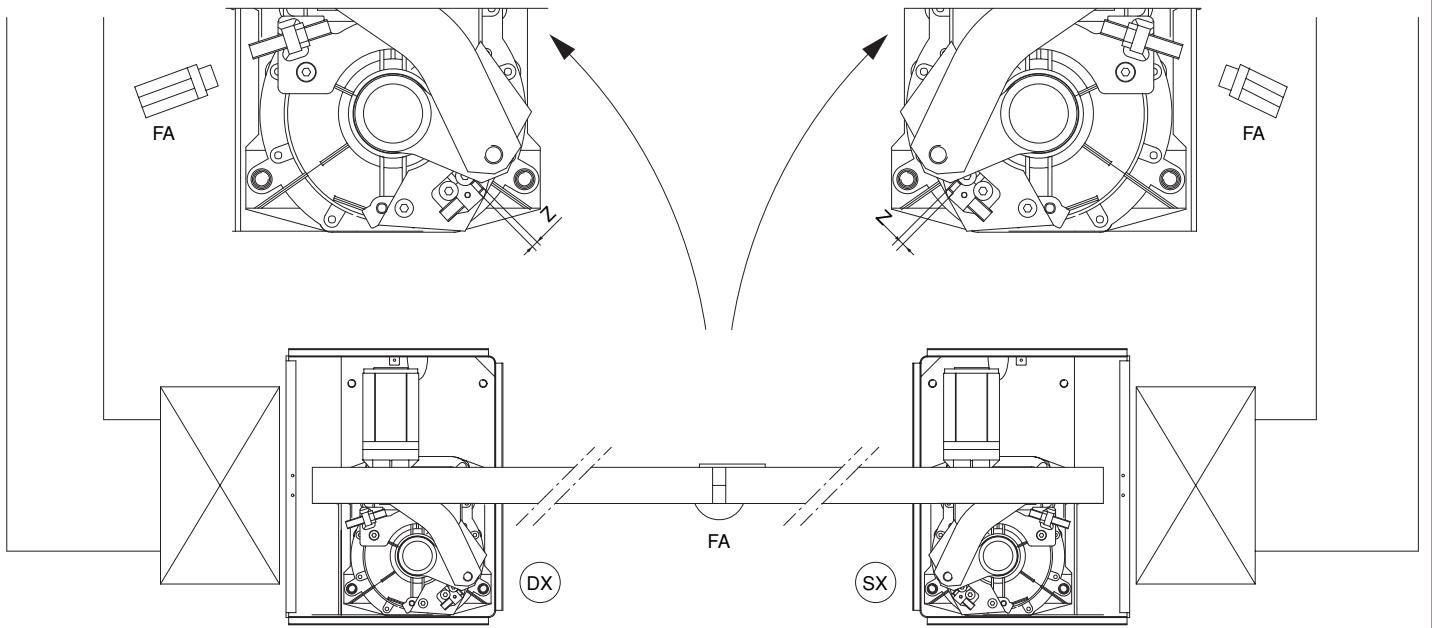
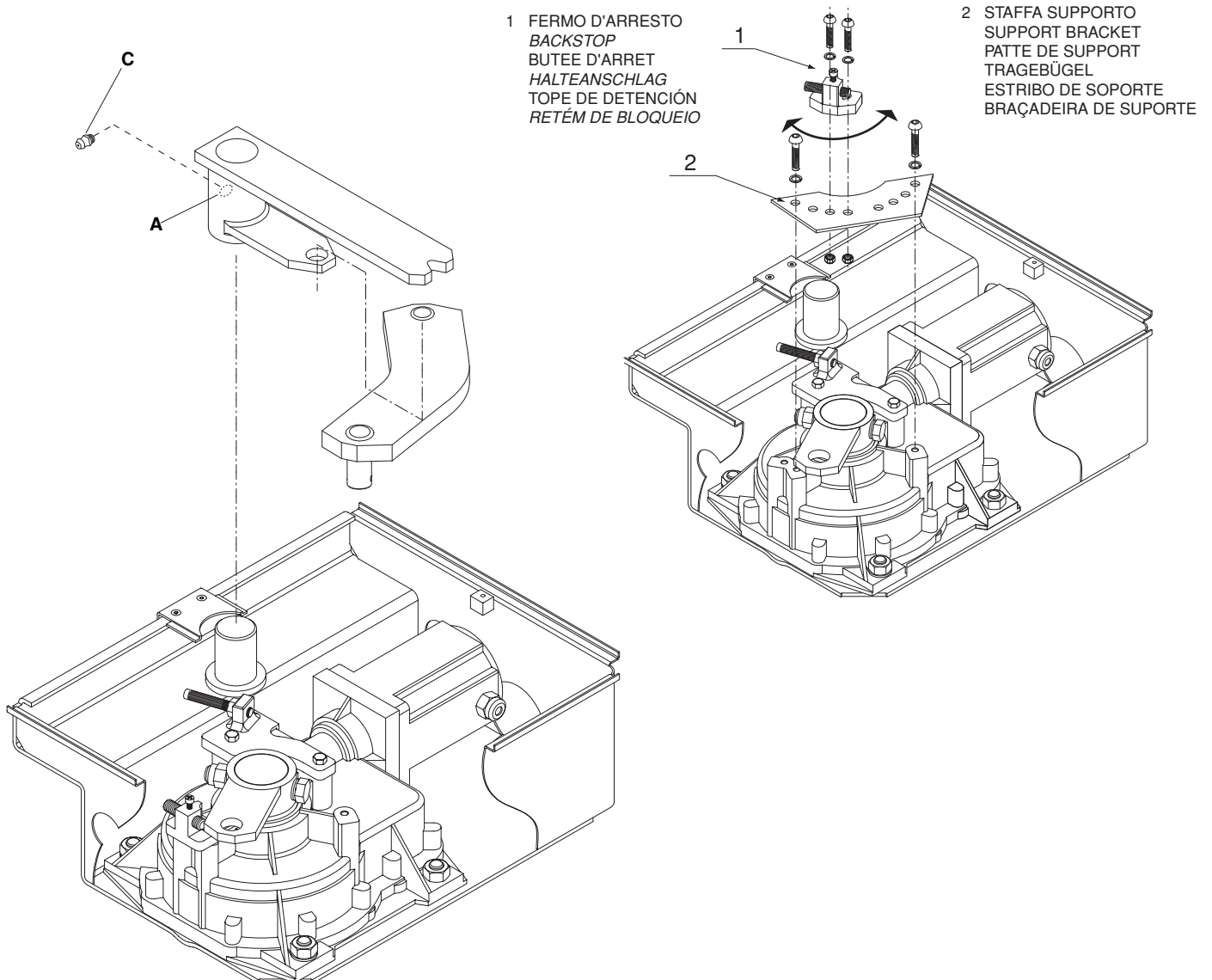

Fig. 9



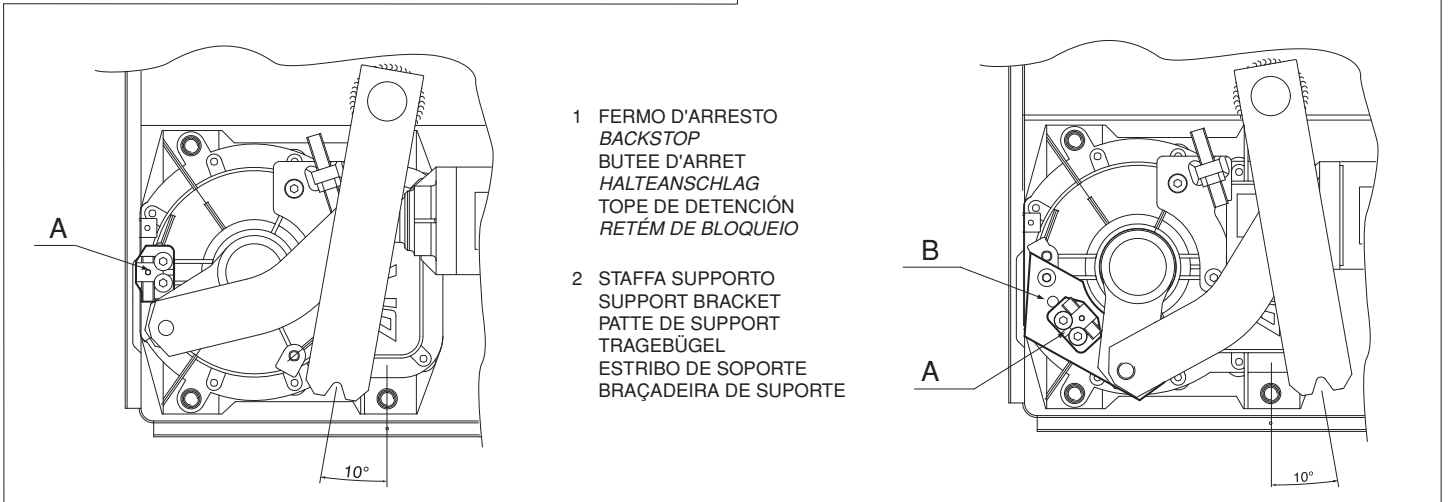
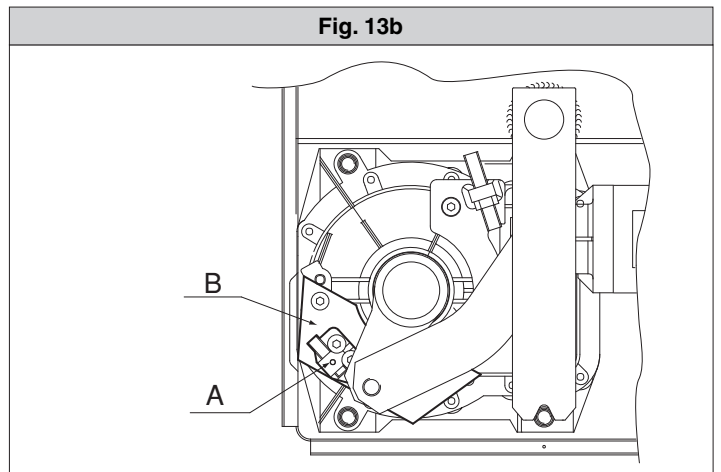
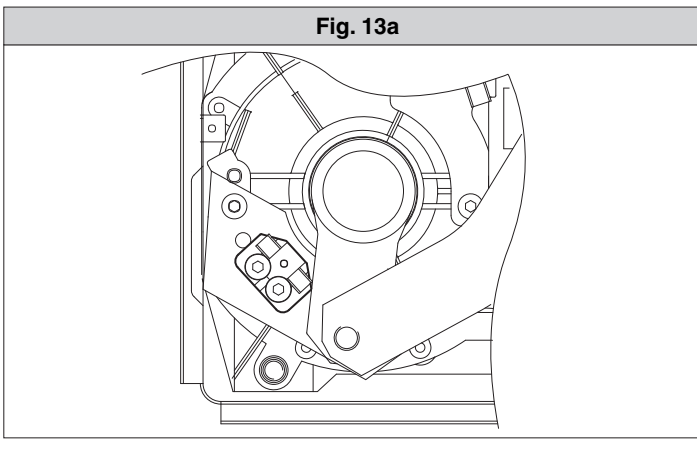
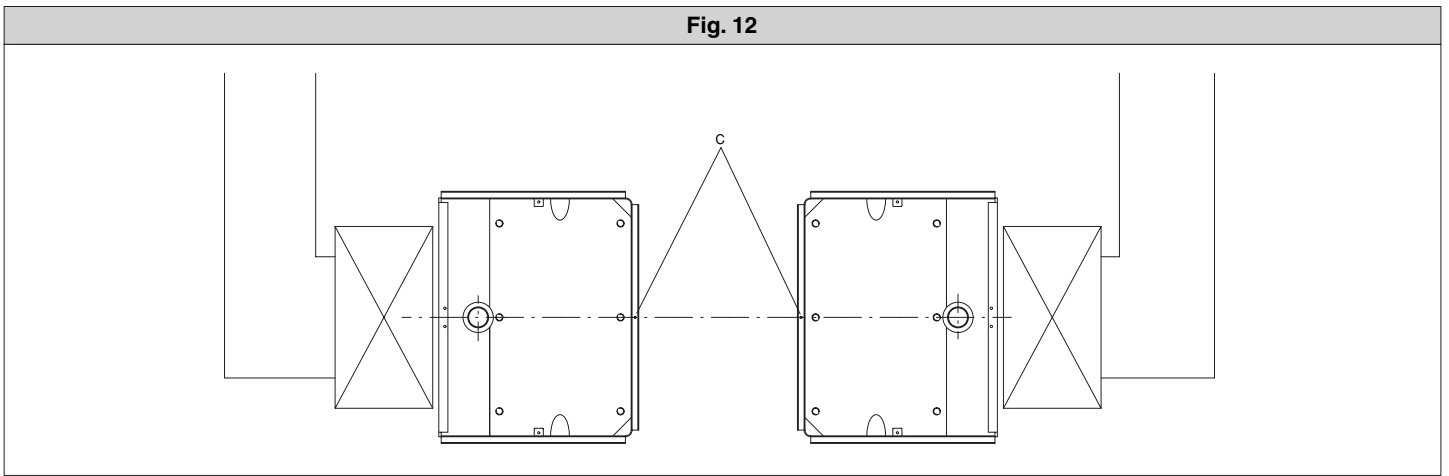
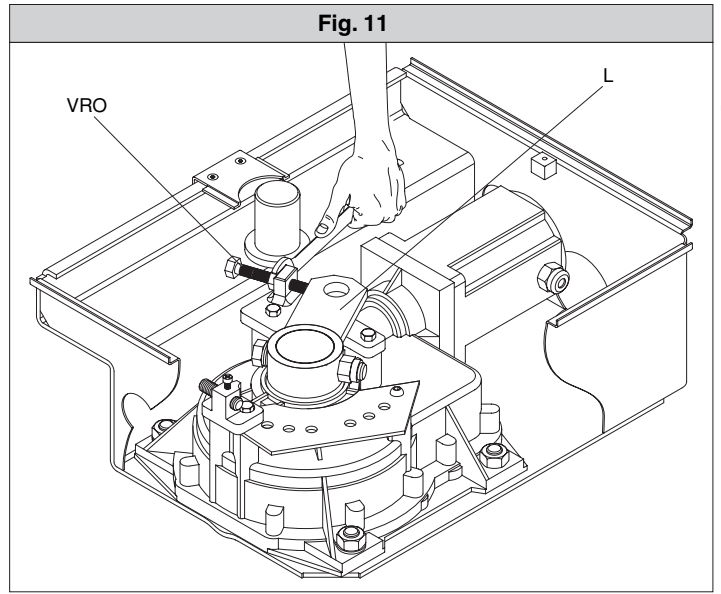
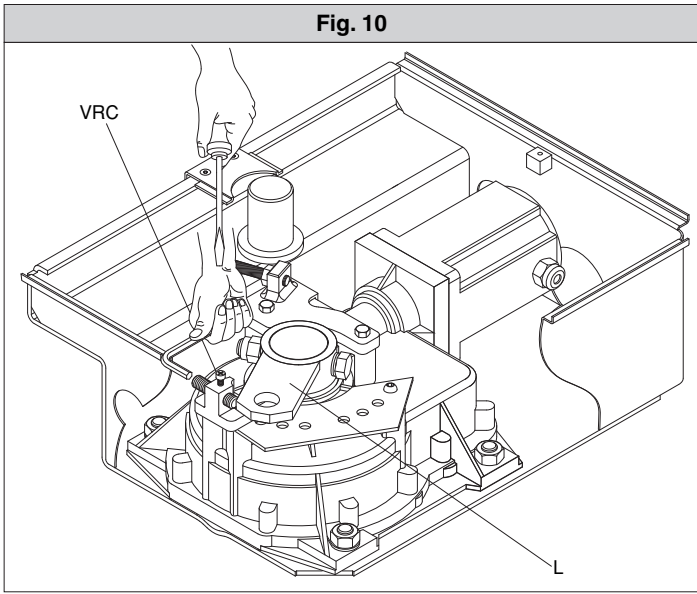
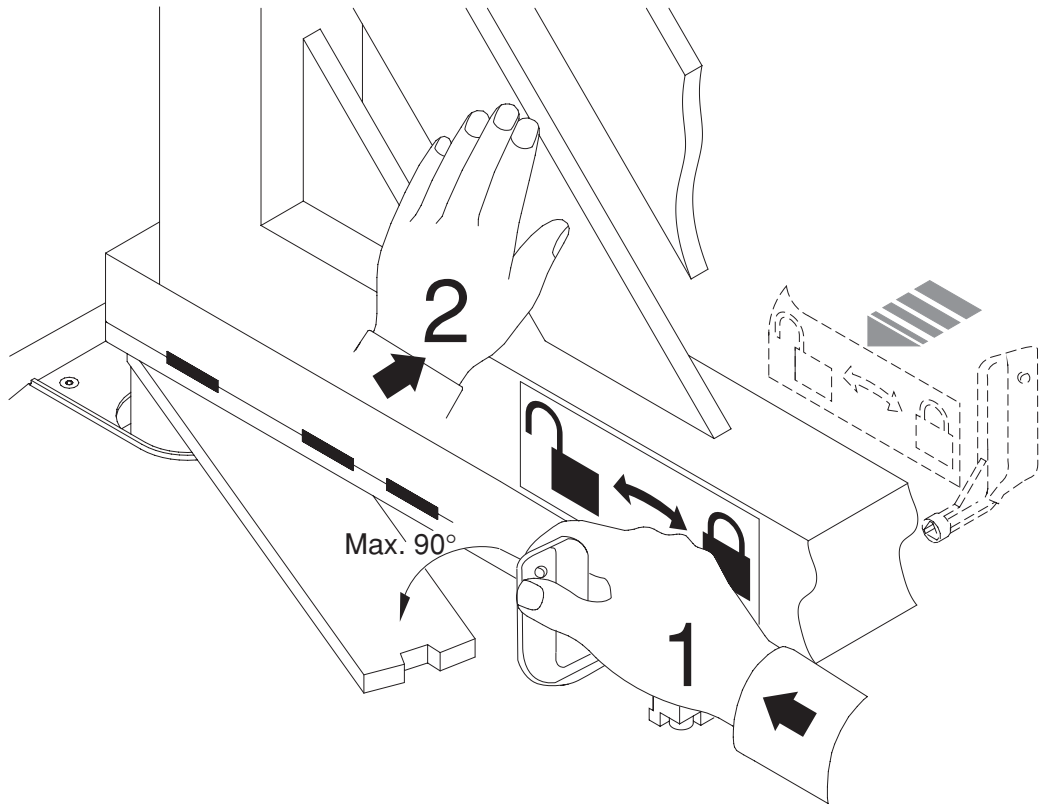
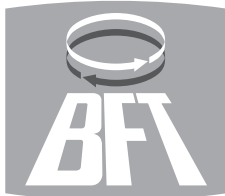

Fig. 14



BFT S.P.A.

Via Lago di Vico 44
36015 Schio (VI) / *Italy*
Tel. 0039 445.696511 - Fax 0039 445.696522
www.bft.it - e-mail: sales@bft.it

**BFT TORANTRIEBSSYSTEME GmbH**

Faber-Castell Str. 29
90522 Oberasbach / *Germany*
Tel. 0049 911 7660090 - Fax 0049 911 7660099
e-mail: service@bft-torantriebe.de

BFT AUTOMATION UK LTD

Unit 8E, Newby Road
Industrial Estate Hazel Grove
Stockport SK7 5DA / *England*
Tel. 0044 161 4560456 - Fax 0044 161 4569090
e-mail: info@bft.co.uk

AUTOMATISMES BFT FRANCE

13 Bdl. E. Michelet
69008 Lyon / *France*
Tel. 0033 4 78 76 09 88 - Fax 0033 4 78 76 92 23
e-mail: infofrance@bft.it

BFT BENELUX SA

Rue du commerce 12
1400 Nivelles / *Belgium*
Tel. 0032 67/ 55 02 00 - Fax 0032 67/ 55 02 01
mail: info@bftbenelux.be

BFT-ADRIA d.o.o.

Obrovac 39
51218 Dražice (RIJEKA) / *Croatia*
Tel. 00385 51 502 640 - Fax 00385 51 502 644
www.bft.hr - e-mail: info@bft.hr

BFT Polska Sp. z o.o.

ul. Szatwiowa 47
03-167 Warszawa / *Polska*
Tel. 0048 022 814 12 22 - Fax 0048 022 814 39 18
www.bft.com.pl - e-mail: biuro@bft.com.pl

BFT GROUP**ITALIBERICA DE AUTOMATISMOS S.L.**

España
www.bftautomatismos.com

P.I. Palau Nord, Sector F
C/Cami Can Basa nº 6-8
08400 GRANOLLERS *Barcelona*
Telf. +34 93 8614828 - Fax +34 93 8700394
e-mail: bftbcn@bftautomatismos.com

P.I. Comendador,
C/ informática, Nave 22
19200 AZUQUECA DE HENARES *Guadalajara*
Telf. +34 949 26 32 00 - Fax. +34 949 26 24 51
e-mail: bft@bftautomatismos.com