

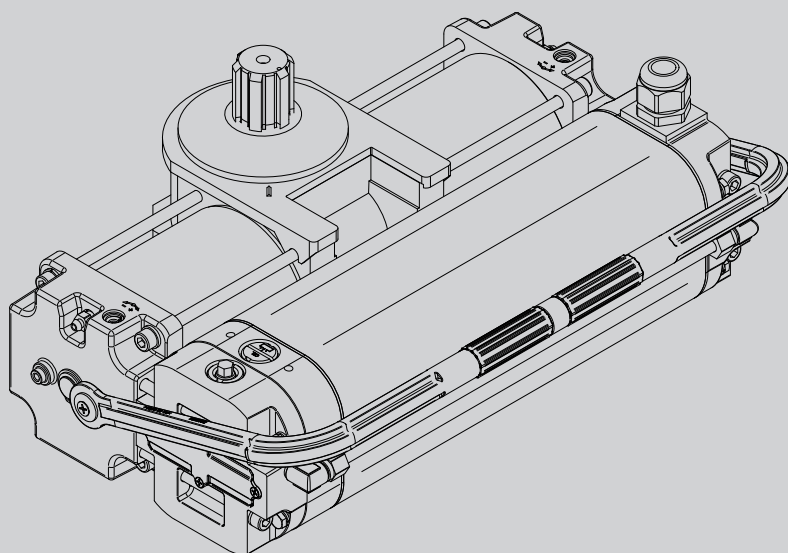

AUTOMAZIONI A PISTONE PER CANCELLI A BATTENTE  
 PISTON AUTOMATIONS FOR SWING GATES  
 AUTOMATIONS A PISTON POUR PORTAILS BATTANTS  
 HYDRAULISCHER DREHTORANTRIEB  
 AUTOMATIZACIONES A PISTON PARA PORTONES CON BATIENTE  
 AUTOMATISERINGSSYSTEMEN MET ZUIGER VOOR VLEUGELPOORTEN



# SUB BT

ISTRUZIONI DI INSTALLAZIONE  
 INSTALLATION MANUAL  
 INSTRUCTIONS D'INSTALLATION  
 MONTAGEANLEITUNG  
 INSTRUCCIONES DE INSTALACION  
 INSTALLATIEVOORSCHRIFTEN



AZIENDA CON SISTEMA DI GESTIONE  
 INTEGRATO CERTIFICATO DA DNV  
 = UNI EN ISO 9001:2008 =  
 UNI EN ISO 14001:2004

# INSTALLAZIONE VELOCE-QUICK INSTALLATION-INSTALLATION RAPIDE SCHNELLINSTALLATION-INSTALACIÓN RÁPIDA - SNELLE INSTALLATIE



- a) Prima di iniziare con l'installazione bisogna leggere le avvertenze.  
 a) Before commencing installation, make sure you read the warnings.  
 a) Avant de commencer l'installation lisez les avertissements.  
 a) Vor der Installation müssen die Hinweise gelesen werden.  
 a) Antes de comenzar con la instalación es necesario leer las advertencias.  
 a) Voor met de installatie te beginnen moet u de waarschuwingen lezen.
- b) Oltre alle figure, bisogna seguire le indicazioni date nel paragrafo corrispondente a pag.10  
 b) In addition to the figures, you must follow the instructions given in the relevant section on page 12  
 b) Suivez non seulement les figures mais aussi les indications données dans le paragraphe correspondant à la page 14  
 b) Außer den Abbildungen müssen die Angaben im entsprechenden Abschnitt auf Seite 16 befolgt werden  
 b) Además de las figuras, es necesario seguir las indicaciones dadas en el apartado correspondiente en pág. 18  
 b) Volg niet alleen de figuren, maar ook de aanwijzingen die in de paragraaf op pag. 20 staan

DB11781 00100\_03

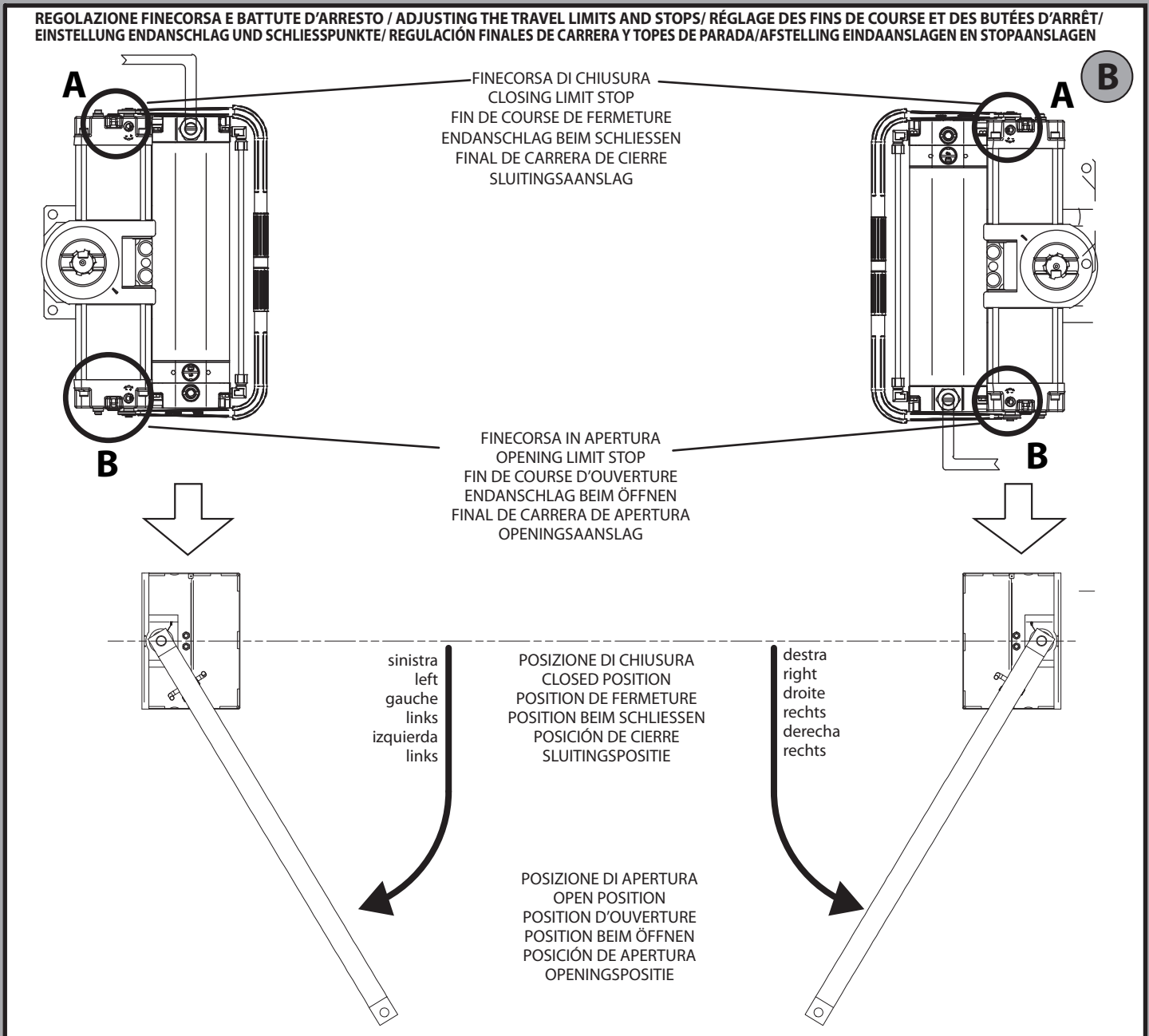
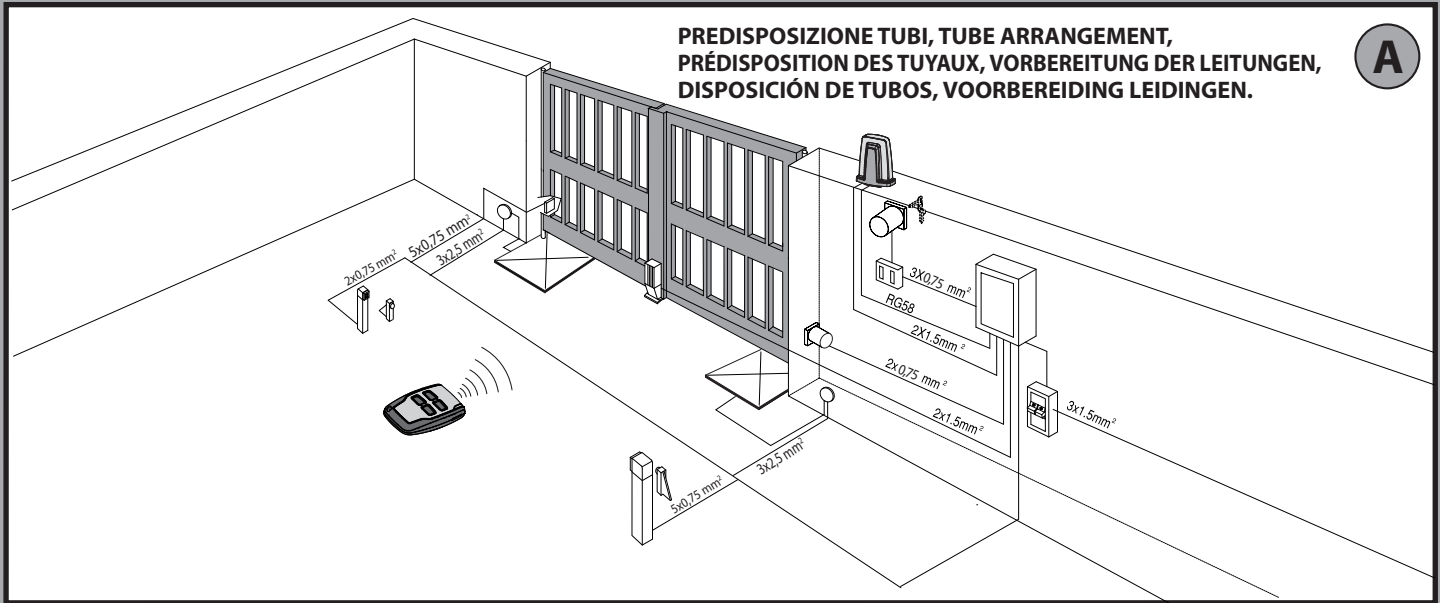

**B1**

ITALIANO

ENGLISH

FRANÇAIS

DEUTSCH

ESPAÑOL

NEDERLANDS

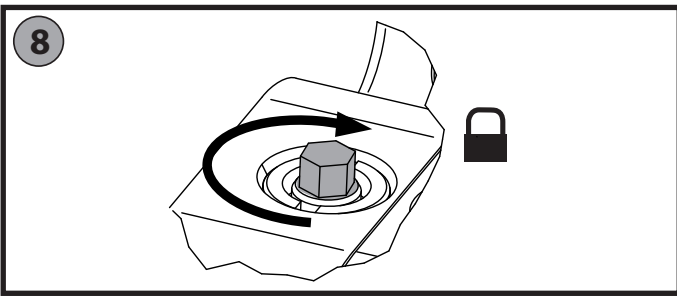
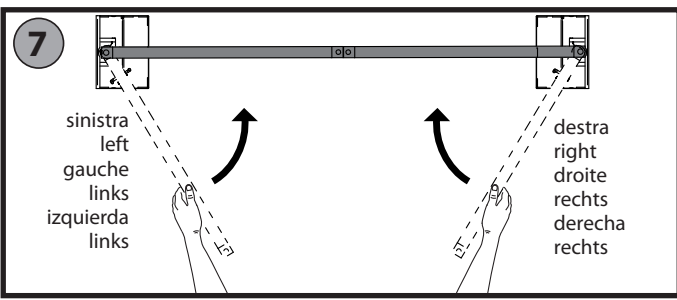
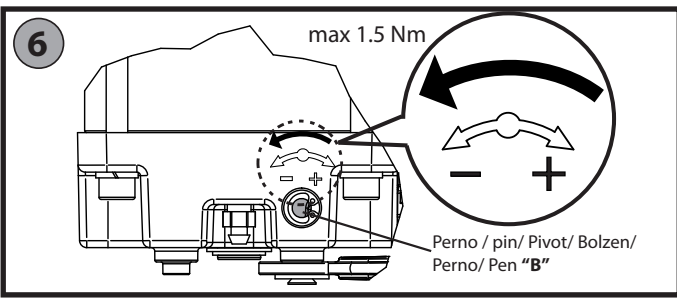
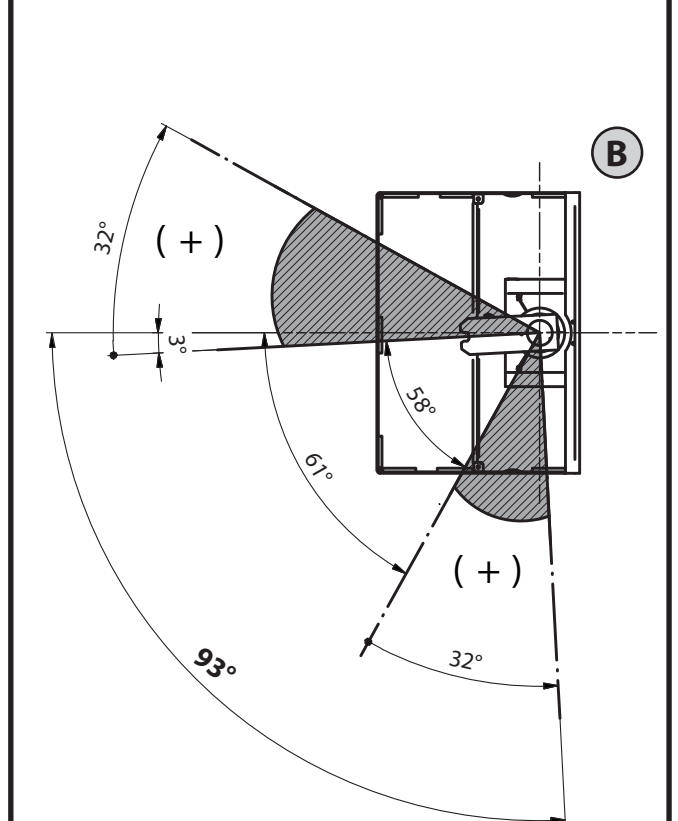
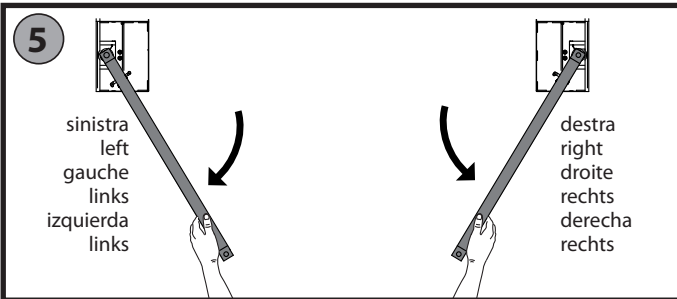
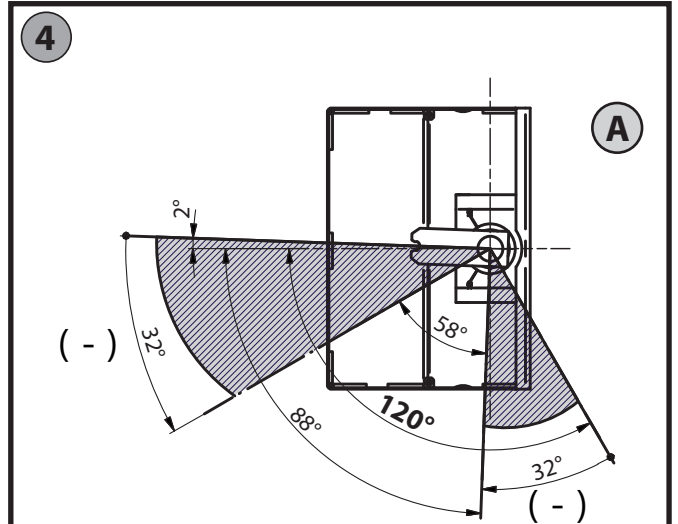
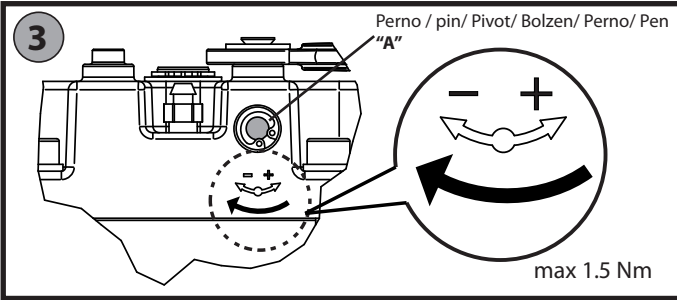
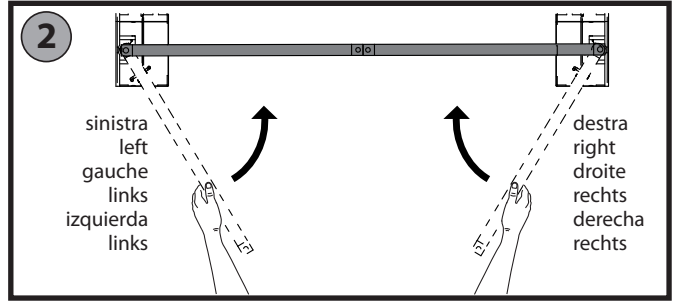
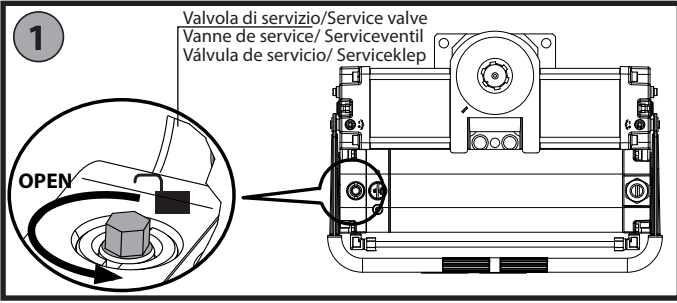

**C**

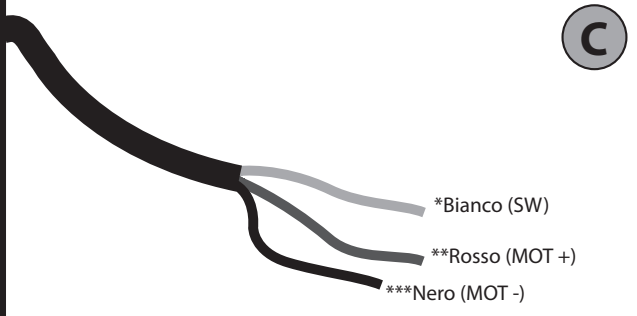

\*Bianco (SW)  
 \*\*Rosso (MOT +)  
 \*\*\*Nero (MOT -)

*Bianco	**Rosso	***Nero
White	Red	Black
Blanc	Rouge	Noir
Weiß	Rot	Nero
Blanco	Rojo	Negro
Wit	Rood	Zwart

**D**

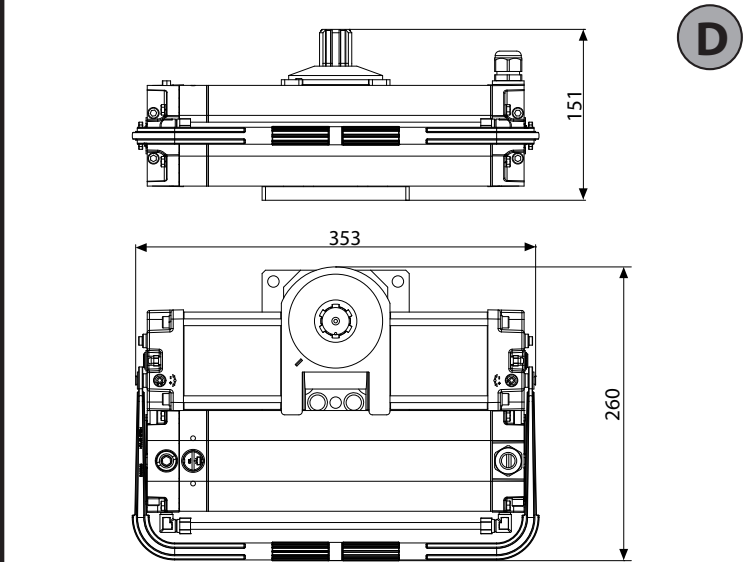

151  
 353  
 260

**E**

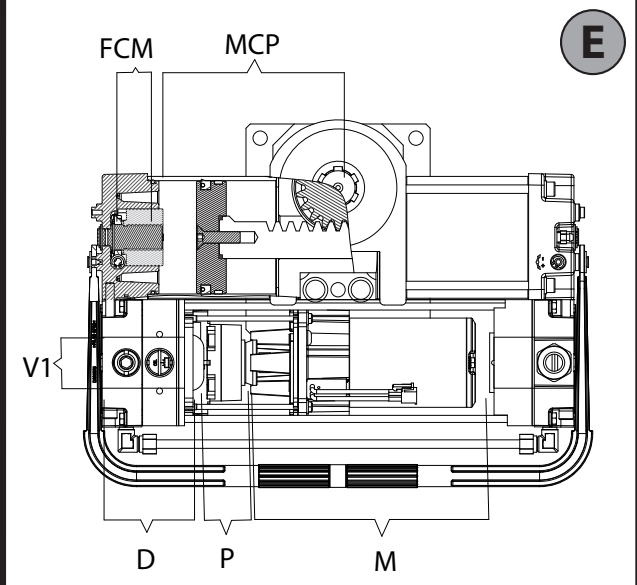

FCM MCP  
 V1  
 D P M

**F**

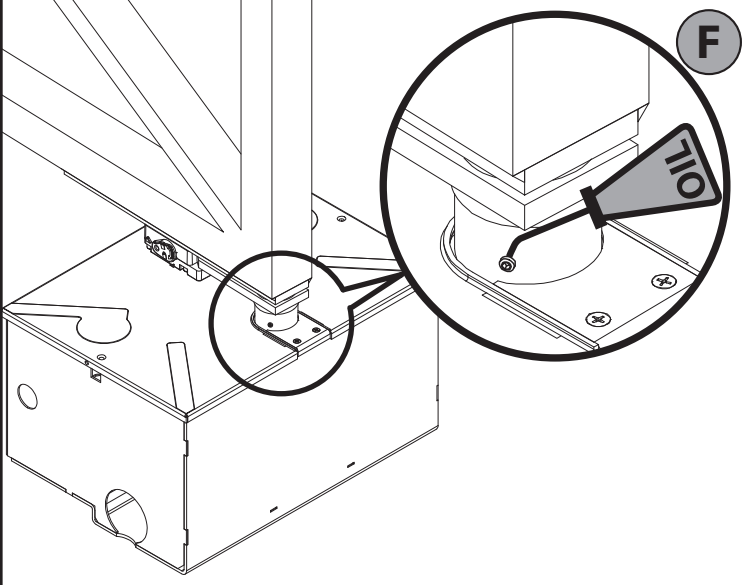

710

**G**

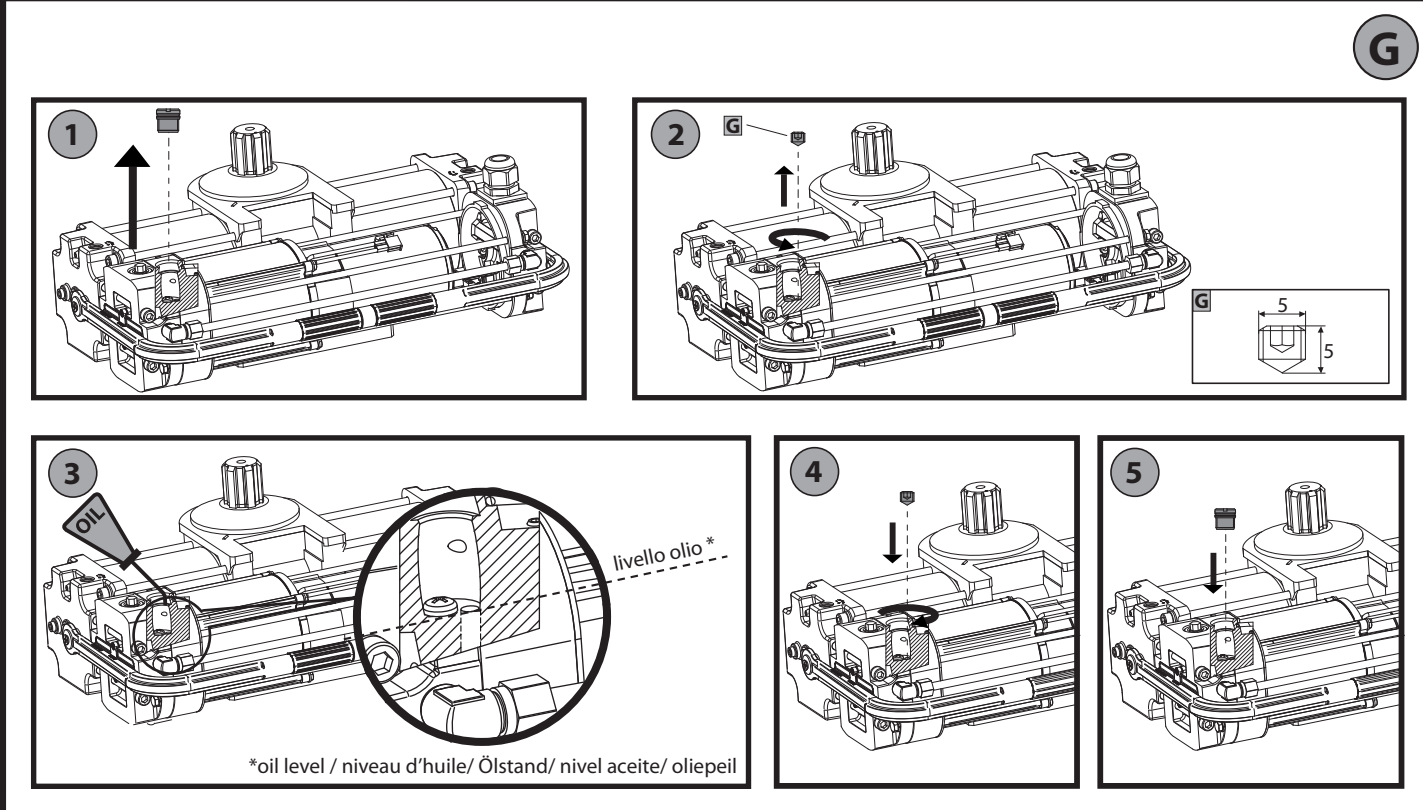

1  
 2  
 3  
 4  
 5

OIL

livello olio \*

\*oil level / niveau d'huile/ Ölstand/ nivel aceite/ oliepeil

G 5 5

## INSTALLER WARNINGS

**WARNING! Important safety instructions. Carefully read and comply with all the warnings and instructions that come with the product as incorrect installation can cause injury to people and animals and damage to property. The warnings and instructions give important information regarding safety, installation, use and maintenance. Keep hold of instructions so that you can attach them to the technical file and keep them handy for future reference.**

### GENERAL SAFETY

This product has been designed and built solely for the purpose indicated herein. Uses other than those indicated herein might cause damage to the product and create a hazard.

- The units making up the machine and its installation must meet the requirements of the following European Directives, where applicable: 2004/108/EC, 2006/95/EC, 2006/42/EC, 89/106/EC, 99/05/EC and later amendments. For all countries outside the EEC, it is advisable to comply with the standards mentioned, in addition to any national standards in force, to achieve a good level of safety.
- The Manufacturer of this product (hereinafter referred to as the "Firm") disclaims all responsibility resulting from improper use or any use other than that for which the product has been designed, as indicated herein, as well as for failure to apply Good Practice in the construction of entry systems (doors, gates, etc.) and for deformation that could occur during use.
- Before installing the product, make all structural changes required to produce safety gaps and to provide protection from or isolate all crushing, shearing and dragging hazard areas and danger zones in general in accordance with the provisions of standards EN 12604 and 12453 or any local installation standards. Check that the existing structure meets the necessary strength and stability requirements.
- Before commencing installation, check the product for damage.
- The Firm is not responsible for failure to apply Good Practice in the construction and maintenance of the doors, gates, etc. to be motorized, or for deformation that might occur during use.
- Make sure the stated temperature range is compatible with the site in which the automated system is due to be installed.
- Do not install this product in an explosive atmosphere: the presence of flammable fumes or gas constitutes a serious safety hazard.
- Disconnect the electricity supply before performing any work on the system. Also disconnect buffer batteries, if any are connected.
- Before connecting the power supply, make sure the product's ratings match the mains ratings and that a suitable residual current circuit breaker and overcurrent protection device have been installed upline from the electrical system. Have the automated system's mains power supply fitted with a switch or omnipolar thermal-magnetic circuit breaker with a contact separation that meets code requirements.
- Make sure that upline from the mains power supply there is a residual current circuit breaker that trips at no more than 0.03A as well as any other equipment required by code.
- Make sure the earth system has been installed correctly: earth all the metal parts belonging to the entry system (doors, gates, etc.) and all parts of the system featuring an earth terminal.
- Installation must be carried out using safety devices and controls that meet standards EN 12978 and EN 12453.
- Impact forces can be reduced by using deformable edges.
- In the event impact forces exceed the values laid down by the relevant standards, apply electro-sensitive or pressure-sensitive devices.
- Apply all safety devices (photocells, safety edges, etc.) required to keep the area free of impact, crushing, dragging and shearing hazards. Bear in mind the standards and directives in force, Good Practice criteria, intended use, the installation environment, the operating logic of the system and forces generated by the automated system.
- Apply all signs required by current code to identify hazardous areas (residual risks). All installations must be visibly identified in compliance with the provisions of standard EN 13241-1.
- Once installation is complete, apply a nameplate featuring the door/gate's data.
- This product cannot be installed on leaves incorporating doors (unless the motor can be activated only when the door is closed).
- If the automated system is installed at a height of less than 2.5 m or is accessible, the electrical and mechanical parts must be suitably protected.
- Install any fixed controls in a position where they will not cause a hazard, away from moving parts. More specifically, hold-to-run controls must be positioned within direct sight of the part being controlled and, unless they are key operated, must be installed at a height of at least 1.5 m and in a place where they cannot be reached by the public.
- Apply at least one warning light (flashing light) in a visible position, and also attach a Warning sign to the structure.
- Attach a label near the operating device, in a permanent fashion, with information on how to operate the automated system's manual release.
- Make sure that, during operation, mechanical risks are avoided or relevant protective measures taken and, more specifically, that nothing can be banged, crushed, caught or cut between the part being operated and surrounding parts.
- Once installation is complete, make sure the motor automation settings are correct and that the safety and release systems are working properly.
- Only use original spare parts for any maintenance or repair work. The Firm disclaims all responsibility for the correct operation and safety of the automated system if parts from other manufacturers are used.
- Do not make any modifications to the automated system's components unless explicitly authorized by the Firm.
- Instruct the system's user on what residual risks may be encountered, on the control systems that have been applied and on how to open the system manually in an emergency. Give the user guide to the end user.
- Dispose of packaging materials (plastic, cardboard, polystyrene, etc.) in accordance with the provisions of the laws in force. Keep nylon bags and polystyrene out of reach of children.

### WIRING

**WARNING!** For connection to the mains power supply, use: a multicore cable with a cross-sectional area of at least 5x1.5mm<sup>2</sup> or 4x1.5mm<sup>2</sup> when dealing with three-phase power supplies or 3x1.5mm<sup>2</sup> for single-phase supplies (by way of example, type H05 VV-F cable can be used with a cross-sectional area of 4x1.5mm<sup>2</sup>). To connect auxiliary equipment, use wires with a cross-sectional area of at least 0.5 mm<sup>2</sup>.

- Only use pushbuttons with a capacity of 10A-250V or more.
- Wires must be secured with additional fastening near the terminals (for example, using cable clamps) in order to keep live parts well separated from safety extra low voltage parts.
- During installation, the power cable must be stripped to allow the earth wire to be connected to the relevant terminal, while leaving the live wires as short as possible. The earth wire must be the last to be pulled taut in the event the cable's fastening device comes loose.

**WARNING!** safety extra low voltage wires must be kept physically separate from low voltage wires.

Only qualified personnel (professional installer) should be allowed to access live parts.

### CHECKING THE AUTOMATED SYSTEM AND MAINTENANCE

Before the automated system is finally put into operation, and during maintenance work, perform the following checks meticulously:

- Make sure all components are fastened securely.
- Check starting and stopping operations in the case of manual control.
- Check the logic for normal or personalized operation.
- For sliding gates only: check that the rack and pinion mesh correctly with 2 mm of play along the full length of the rack; keep the track the gate slides on clean and free of debris at all times.
- For sliding gates and doors only: make sure the gate's running track is straight and horizontal and that the wheels are strong enough to take the weight of the gate.
- For cantilever sliding gates only: make sure there is no dipping or swinging during operation.
- For swing gates only: make sure the leaves' axis of rotation is perfectly vertical.
- Check that all safety devices (photocells, safety edges, etc.) are working properly and that the anti-crush safety device is set correctly, making sure that the force of impact measured at the points provided for by standard EN 12445 is lower than the value laid down by standard EN 12453.
- Impact forces can be reduced by using deformable edges.
- Make sure that the emergency operation works, where this feature is provided.
- Check opening and closing operations with the control devices applied.
- Check that electrical connections and cabling are intact, making extra sure that insulating sheaths and cable glands are undamaged.
- While performing maintenance, clean the photocells' optics.
- When the automated system is out of service for any length of time, activate the emergency release (see "EMERGENCY OPERATION" section) so that the operated part is made idle, thus allowing the gate to be opened and closed manually.
- If the power cord is damaged, it must be replaced by the manufacturer or their technical assistance department or other such qualified person to avoid any risk.
- If "D" type devices are installed (as defined by EN 12453), connect in unverified mode, foresee mandatory maintenance at least every six months

### WARNING!

Remember that the drive is designed to make the gate/door easier to use and will not solve problems as a result of defective or poorly performed installation or lack of maintenance

### SCRAPPING

Materials must be disposed of in accordance with the regulations in force. There are no particular hazards or risks involved in scrapping the automated system. For the purpose of recycling, it is best to separate dismantled parts into like materials (electrical parts - copper - aluminium - plastic - etc.).

### DISMANTLING

If the automated system is being dismantled in order to be reassembled at another site, you are required to:

- Cut off the power and disconnect the whole electrical system.
- Remove the actuator from the base it is mounted on.
- Remove all the installation's components.
- See to the replacement of any components that cannot be removed or happen to be damaged.

**Anything that is not explicitly provided for in the installation manual is not allowed. The operator's proper operation can only be guaranteed if the information given is complied with. The Firm shall not be answerable for damage caused by failure to comply with the instructions featured herein.**

**While we will not alter the product's essential features, the Firm reserves the right, at any time, to make those changes deemed opportune to improve the product from a technical, design or commercial point of view, and will not be required to update this publication accordingly.**

## 1) GENERAL INFORMATION

The SUB BT hydraulic actuator is ideal for in-ground under-hinge applications. It is a brilliant solution to the problem of making the automated system aesthetically unobtrusive. The SUB BT actuator comes as a waterproof self-contained unit incorporating the hydraulic power pack-jack, which means it can be installed fully under ground without the need for any hydraulic connections.

The gate is kept closed by a hydraulic locking feature or by a solenoid lock. The actuator features soft-closing so that the gate opens and closes without clanging; operating force is adjusted automatically and extremely accurately by means of the control unit's electronic control. The actuator features built-in mechanical limit stops that can be adjusted over the last 32 degrees of the gate's opening and closing travel to make the installer's job easier and also avoid having to install external mechanical stops.

2) TECHNICAL SPECIFICATIONS	
Power supply (*)	24V ---
Max. power input	300W
Max. pressure	30 bar
Pump delivery rate	0,9 l/min.
Max. torque	400 Nm
Type of use	very intensive
Type of locking	Hydraulic
Ambient temperature range	-20°C to 60°C
Impact reaction	electronic clutch (with control panel)
Manual operation	release key
Protection rating	IP 67
Actuator weight	16 kg
Max. leaf weight	800 kg.
Max. leaf length	2.5m (when dealing with leaves over 2 m long, use the solenoid lock)(*1)
Max. opening angle	120°
Angular velocity	9°/s
Overall dimensions	Fig. D
Oil	Idrolux Winter

(\*) Special supply voltages to order.

(\*1) **CAUTION!!! for correct operation, use the floor-mounted stops.**

**CAUTION!!! If you are using two solenoid locks in the installation, you will need to run the second lock off a separate power supply.**

## 3) TUBE ARRANGEMENT FIG. A

### 4) ADJUSTING THE TRAVEL LIMITS AND STOPS FIG. B:

 **Warning!** Do not attempt to move the leaf using the limit stop adjustment screw.

 **WARNING!** Make sure that the leaf approaches the opening and closing travel limits at slowed speed.

Turning pin "A" (- direction) --> leaf angle decreases.

Turning pin "B" (+ direction) --> leaf angle increases.

The pin can be turned manually or with a battery-powered screwdriver set to 1.5 Nm.

13 turns of pin "A" = limit stop moved by 1.5 mm ≈ 3° Leaf (opening-closing). Total FCM1 movement: 15 mm ≈ 32°.

#### FIG. B1:

- Release the operator by opening the service valve (Ref. 1).
- Close the leaf (manually) (Ref. 2).
- Turn the closing limit stop pin "A" as far as it will go in the (-) direction (Ref. 3).
- Sample adjustments (Ref. 4):
  - up to 120° (Ref. A)
  - up to 93° (Ref. B).
- Open the leaf manually (to the desired position) (Ref. 5).
- Turn the opening limit stop pin "B" as far as it will go in the (-) direction (Ref. 6).

- Open and close both gate leaves to check that the limit stops are adjusted correctly.
- Close the leaf (manually) (Ref. 7).
- Lock the operator again by closing the service valve (Ref. 8)

## 5) POWER CABLE FIG. C

## 6) MAIN PARTS OF AUTOMATED SYSTEM FIG. E

**FCM:** motor limit stop

**MCP:** jack, rack, pinion

**M:** motor

**P:** hydraulically driven lobe pump

**D:** control valve assembly

**V1:** service valve

### MAINTENANCE:

#### 7) LUBRICATING THE SERVICE VALVE Fig. F

Caution: this operation needs to be performed every 12 months.

#### 7.1) TOPPING UP OIL FIG. G

Caution: an oil change is recommended every 5 years.

## 8) MANUAL OPENING (See USER GUIDE -FIG. 1-).

**FIG.1 ATTIVAZIONE SBLOCCO DI EMERGENZA / ACTIVATING EMERGENCY RELEASE.**  
**ACTIVATION DU DÉVERROUILLAGE D'URGENCE / AKTIVIERUNG NOTFALLENTSPERRUNG.**  
**ACTIVACIÓN DEL DESBLOQUEO DE EMERGENCIA / ACTIVERING NOOD-DEBLOKKERING.**

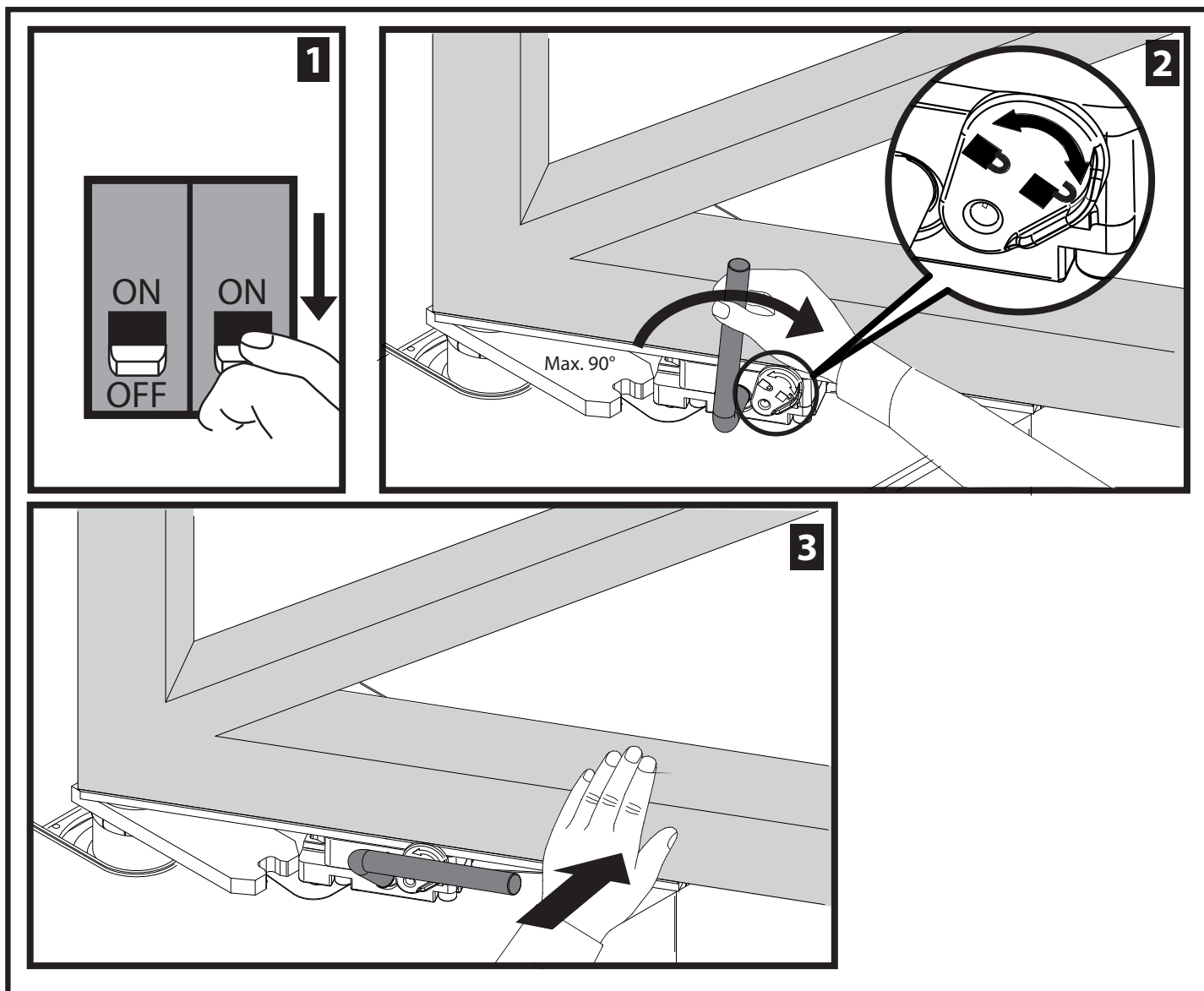

**AVVERTENZE PER L'UTILIZZATORE ( I )**

**ATTENZIONE! Importanti istruzioni di sicurezza. Leggere e seguire attentamente le Avvertenze e le Istruzioni che accompagnano il prodotto poiché un uso improprio può causare danni a persone, animali o cose. Conservare le istruzioni per consultazioni future e trasmetterle ad eventuali subentranti nell'uso dell'impianto.**

**Questo prodotto dovrà essere destinato solo all'uso per il quale è stato espressamente installato. Ogni altro uso è da considerarsi improprio e quindi pericoloso. Il costruttore non può essere considerato responsabile per eventuali danni causati da usi impropri, erronei e irragionevoli.**

**SICUREZZA GENERALE**

Nel ringraziarVi per la preferenza accordata a questo prodotto, la Ditta è certa che da esso otterrete le prestazioni necessarie al Vostro uso.

Questo prodotto risponde alle norme riconosciute della tecnica e della disposizioni relative alla sicurezza se correttamente installato da personale qualificato ed esperto (installatore professionale).

L'automazione, se installata ed utilizzata correttamente, soddisfa gli standard di sicurezza nell'uso. Tuttavia è opportuno osservare alcune regole di comportamento per evitare inconvenienti accidentali:

- Tenere bambini, persone e cose fuori dal raggio d'azione dell'automazione, in particolare durante il movimento.
- Non permettere a bambini di giocare o sostare nel raggio di azione dell'automazione.
- Questa automazione non è destinata all'uso da parte di bambini o da parte di persone con ridotte capacità mentali, fisiche e sensoriali, o persone che manca-

no di conoscenze adeguate a meno che esse non abbiano potuto beneficiare, attraverso l'intermediazione di una persona responsabile della loro sicurezza, di una sorveglianza o di istruzioni riguardanti l'uso dell'apparecchio.

- I bambini devono essere sorvegliati per sincerarsi che non giochino con l'apparecchio. Non permettere ai bambini di giocare con i controlli fissi. Tenere i telecomandi lontani dai bambini.
- Evitare di operare in prossimità delle cerniere o organi meccanici in movimento.
- Non contrastare il movimento dell'anta e non tentare di aprire manualmente la porta se non è stato sbloccato l'attuatore con l'apposita manopola di sblocco.
- Non entrare nel raggio di azione della porta o cancello motorizzati durante il loro movimento.
- Non lasciare radiocomandi o altri dispositivi di comando alla portata dei bambini onde evitare azionamenti involontari.
- L'attivazione dello sblocco manuale potrebbe causare movimenti incontrollati della porta se in presenza di guasti meccanici o di condizioni di squilibrio.
- In caso di apritapparelle: sorvegliare la tapparella in movimento e tenere lontano le persone finché non è completamente chiusa. Porre cura quando si aziona lo sblocco se presente, poiché una tapparella aperta potrebbe cadere rapidamente in presenza di usura o rotture.
- La rottura o l'usura di organi meccanici della porta (parte guidata), quali ad esempio cavi, molle, supporti, cardini, guide... potrebbe generare pericoli. Far controllare periodicamente l'impianto da personale qualificato ed esperto (installatore professionale) secondo quanto indicato dall'installatore o dal costruttore della porta.
- Per ogni operazione di pulizia esterna, togliere l'alimentazione di rete.
- Tenere pulite le ottiche delle fotocellule ed i dispositivi di segnalazione luminosa. Controllare che rami ed arbusti non disturbino i dispositivi di sicurezza.

- Non utilizzare l'automatismo se necessita di interventi di riparazione. In caso di guasto o di malfunzionamento dell'automazione, togliere l'alimentazione di rete sull'automazione, astenersi da qualsiasi tentativo di riparazione o intervento diretto e rivolgersi solo a personale qualificato ed esperto (installatore professionale) per la necessaria riparazione o manutenzione. Per consentire l'accesso, attivare lo sblocco di emergenza (se presente).
- Per qualsiasi intervento diretto sull'automazione o sull'impianto non previsto dal presente manuale, avvalersi di personale qualificato ed esperto (installatore professionale).
- Con frequenza almeno annuale far verificare l'integrità e il corretto funzionamento dell'automazione da personale qualificato ed esperto (installatore professionale), in particolare di tutti i dispositivi di sicurezza.
- Gli interventi d'installazione, manutenzione e riparazione devono essere documentati e la relativa documentazione tenuta a disposizione dell'utilizzatore.
- Il mancato rispetto di quanto sopra può creare situazioni di pericolo.

**Tutto quello che non è espressamente previsto nel manuale d'uso, non è permesso. Il buon funzionamento dell'operatore è garantito solo se vengono rispettate le prescrizioni riportate in questo manuale. La Ditta non risponde dei danni causati dall'inosservanza delle indicazioni riportate in questo manuale.**

**Lasciando inalterate le caratteristiche essenziali del prodotto, la Ditta si riserva di apportare in qualunque momento le modifiche che essa ritiene convenienti per migliorare tecnicamente, costruttivamente e commercialmente il prodotto, senza impegnarsi ad aggiornare la presente pubblicazione.**

## USER WARNINGS (GB)

**WARNING! Important safety instructions. Carefully read and comply with the Warnings and Instructions that come with the product as improper use can cause injury to people and animals and damage to property. Keep the instructions for future reference and hand them on to any new users. This product is meant to be used only for the purpose for which it was explicitly installed. Any other use constitutes improper use and, consequently, is hazardous. The manufacturer cannot be held liable for any damage as a result of improper, incorrect or unreasonable use.**

### GENERAL SAFETY

Thank you for choosing this product. The Firm is confident that its performance will meet your operating needs.

This product meets recognized technical standards and complies with safety provisions when installed correctly by qualified, expert personnel (professional installer).

If installed and used correctly, the automated system will meet operating safety standards. Nonetheless, it is advisable to observe certain rules of behaviour so that accidental problems can be avoided:

- Keep adults, children and property out of range of the automated system, especially while it is moving.
- Do not allow children to play or stand within range of the automated system.
- This automated system is not meant for use by children or by people with impaired mental, physical or sensory capacities, or people who do not have suitable knowledge, unless a person who is responsible for their safety provides them with necessary supervision or instructions on how to use the device.
- Children must be supervised to ensure they do not play with the device. Do not allow children to play with the fixed controls. Keep remote controls out of reach of children.
- Do not work near hinges or moving mechanical parts.
- Do not hinder the leaf's movement and do not attempt to open the door manually unless the actuator has been released with the relevant release knob.
- Keep out of range of the motorized door or gate while they are moving.
- Keep remote controls or other control devices out of reach of children in order to avoid the automated system being operated inadvertently.
- The manual release's activation could result in uncontrolled door movements if there are mechanical faults or loss of balance.
- When using roller shutter openers: keep an eye on the roller shutter while it is moving and keep people away until it has closed completely. Exercise care when activating the release, if such a device is fitted, as an open shutter could drop quickly in the event of wear or breakage.
- The breakage or wear of any mechanical parts of the door (operated part), such as cables, springs, supports, hinges, guides... , may generate a hazard. Have the system checked by qualified, expert personnel (professional installer) at regular intervals according to the instructions issued by the installer or manufacturer of the door.
- When cleaning the outside, always cut off mains power.
- Keep the photocells' optics and illuminating indicator devices clean. Check that no branches or shrubs interfere with the safety devices.
- Do not use the automated system if it is in need of repair. In the event the automated system breaks down or malfunctions, cut off mains power to the system; do not attempt to repair or perform any other work to rectify the fault yourself and instead call in qualified, expert personnel (professional installer) to perform the necessary repairs or maintenance. To allow access, activate the emergency release (where fitted).
- If any part of the automated system requires direct work of any kind that is not contemplated herein, employ the services of qualified, expert personnel (professional installer).
- At least once a year, have the automated system, and especially all safety devices, checked by qualified, expert personnel (professional installer) to make sure that it is undamaged and working properly.

- A record must be made of any installation, maintenance and repair work and the relevant documentation kept and made available to the user on request.
- Failure to comply with the above may result in hazardous situations.

**Anything that is not explicitly provided for in the user guide is not allowed. The operator's proper operation can only be guaranteed if the instructions given herein are complied with. The Firm shall not be answerable for damage caused by failure to comply with the instructions featured herein. While we will not alter the product's essential features, the Firm reserves the right, at any time, to make those changes deemed opportune to improve the product from a technical, design or commercial point of view, and will not be required to update this publication accordingly.**

## AVERTISSEMENTS POUR L'UTILISATEUR (F)

**ATTENTION ! Instructions de sécurité importantes. Veuillez lire et suivre attentivement tous les avertissements et toutes les instructions fournis avec le produit sachant qu'un usage incorrect peut provoquer des préjudices aux personnes, aux animaux ou aux biens. Veuillez conserver les instructions pour d'ultérieures consultations et pour les transmettre aux propriétaires futurs éventuels.**

**Cet appareil ne peut être destiné qu'à l'usage pour lequel il a été expressément installé. Tout autre usage sera considéré comme impropre et donc dangereux. Le fabricant ne sera en aucun cas considéré comme responsable des préjudices dus à un usage impropre, erroné ou déraisonné.**

### SECURITE GÉNÉRALE

Nous vous remercions d'avoir choisi ce produit qui, nous n'en doutons pas, saura vous garantir les performances attendues.

Ce produit, correctement installé par du personnel qualifié et expérimenté (monteur professionnel) est conforme aux normes reconnues de la technique et des prescriptions de sécurité.

Si l'automatisation est montée et utilisée correctement, elle garantit la sécurité d'utilisation prescrite. Il est cependant nécessaire de respecter certaines règles de comportement pour éviter tout inconvénient accidentel.

- Tenir les enfants, les personnes et les objets à l'écart du rayon d'action de l'automatisation, en particulier pendant son fonctionnement.
- Empêcher les enfants de jouer ou de stationner dans le rayon d'action de l'automatisation.
- Cette automatisation n'est pas destinée à être utilisée par des enfants, des personnes ayant des capacités mentales, physiques et sensorielles réduites ou des personnes ne disposant pas des connaissances nécessaires à moins de disposer, par l'entremise d'une personne responsable de leur sécurité, d'une surveillance ou d'instructions sur l'usage de l'appareil.
- Les enfants doivent être surveillés afin de s'assurer qu'ils ne jouent pas avec l'appareil. Interdire aux enfants de jouer avec les contrôles fixes. Ranger les télécommandes hors de portée des enfants.
- Eviter d'opérer à proximité des charnières ou des organes mécaniques en mouvement.
- Ne pas s'opposer volontairement au mouvement du vantail et ne pas tenter d'ouvrir la porte à la main si le déclencheur n'est pas déverrouillé avec le levier de déverrouillage prévu à cet effet.
- Ne pas entrer dans le rayon d'action du portail/de la porte motorisé/e pendant son mouvement.
- Ranger les radiocommandes ou les autres dispositifs de commande hors de portée des enfants afin d'éviter tout actionnement involontaire.
- L'activation du déverrouillage manuel risque de provoquer des mouvements incontrôlés de la porte en présence de pannes mécaniques ou de conditions de déséquilibre.
- Avec les ouvre-stores: surveiller le store en mouvement et veiller à ce que les personnes restent à l'écart tant qu'il n'est pas complètement fermé. Actionner l'éventuel déverrouillage avec prudence car si un store reste ouvert il peut tomber brutalement s'il est usé ou cassé.
- La rupture ou l'usure des organes mécaniques de la porte (partie guidée), tels que les câbles, les ressorts, les supports et les gonds peuvent générer des risques. Faire contrôler périodiquement l'installation par du personnel qualifié et expérimenté (monteur professionnel), conformément aux indications du monteur ou du fabricant de la porte.
- Mettre hors tension avant d'accomplir les opérations de nettoyage extérieur.
- Veiller à la propreté des lentilles des photocellules et des lampes de signalisation. Veiller à ce que les dispositifs de sécurité ne soient pas gênés par des branches ou des arbustes.
- Ne pas utiliser l'automatisation si elle a besoin d'être réparée. En cas de panne ou de mauvais fonctionnement de l'automatisation, mettre l'automatisation hors tension, éviter toute tentative de réparation ou d'intervention directe et s'adresser uniquement à du personnel qualifié et expérimenté (monteur professionnel) pour la réparation ou les opérations d'entretien nécessaires. Pour permettre l'accès, activer le déverrouillage d'urgence (s'il y en a un).
- Pour toutes les interventions directes sur l'automatisation ou sur l'installation non prévues dans le présent manuel, s'adresser uniquement à du personnel qualifié et expérimenté (monteur professionnel).
- Une fois par an au moins, faire vérifier le bon état et le bon fonctionnement de l'automatisation par du personnel qualifié et expérimenté (monteur professionnel) et en particulier tous les dispositifs de sécurité.
- Les interventions de montage, d'entretien et de réparation doivent être documentées et cette documentation doit être tenue à la disposition de l'utilisateur.
- Le non respect des prescriptions ci-dessus peut être à l'origine de dangers.





**Tout ce qui n'est pas expressément prévu dans le manuel de montage est interdit. Le bon fonctionnement de l'appareil n'est garanti que si les données indiquées sont respectées. Le Fabricant ne répond pas des dommages provoqués par l'observation des indications données dans ce manuel. En laissant inaltérées les caractéristiques essentielles de l'appareil, l'entreprise se réserve le droit d'apporter à tout moment les modifications qu'elle jugera opportunes pour améliorer le produit du point de vue technique, commercial et de sa construction, sans s'engager à mettre à jour la présente publication.**

## HINWEISE FÜR DEN BENUTZER (D)

**ACHTUNG! Wichtige Hinweise zur Sicherheit. Bitte lesen und befolgen Sie aufmerksam die Hinweise sowie die Bedienungsanleitung, die das Produkt begleiten, denn eine falsche Benutzung des Produkts kann zu Verletzungen von Menschen und Tieren sowie zu Sachschäden führen. Bitte bewahren Sie die Anweisungen für die zukünftige Konsultation sowie für eventuelle zukünftige Benutzer der Anlage auf.**

**Dieses Produkt ist ausschließlich für den Einsatz bestimmt, für den es ausdrücklich installiert worden ist. Alle sonstigen Einsatzweisen gelten als Zweckentfremdung und somit als gefährlich. Der Hersteller kann nicht für eventuelle Schäden haftbar gemacht werden, die auf Zweckentfremdung oder unsachgemäße Verwendung zurückzuführen sind.**

### ALLGEMEINE SICHERHEIT

Wir danken Ihnen dafür, dass Sie diesem Produkt den Vorzug gegeben haben, und sind sicher, dass Sie mit ihm die für Ihre Anwendung erforderlichen Leistungen erzielen werden.

Dieses Produkt entspricht den anerkannten Normen der Technik sowie den Sicherheitsbestimmungen, falls es von qualifiziertem Fachpersonal (professioneller Installateur) ordnungsgemäß installiert wird.

Bei ordnungsgemäßer Installation und Benutzung erfüllt die Automatisierung die geforderten Sicherheitsstandards. Dennoch sollten einige Verhaltensregeln beachtet werden, um Zwischenfälle zu vermeiden:

- Halten Sie Kinder, Personen und Sachen aus dem Wirkungsbereich der Automatisierung fern, vor allem während der Bewegung.
- Verhindern Sie, dass sich Kindern im Aktionsradius der Automatisierung aufhalten oder dort spielen.
- Diese Automatisierung ist nicht für die Benutzung durch Kinder, Personen mit eingeschränkten geistigen, körperlichen oder sensorischen Fähigkeiten oder Personen ohne angemessene Kenntnisse vorgesehen, es sei denn, sie werden durch ihren Sicherheitsbeauftragten überwacht oder in die Benutzung der Vorrichtung eingewiesen.
- Kinder müssen überwacht werden, um sicherzustellen, dass sie nicht mit der Vorrichtung spielen. Stellen Sie sicher, dass die Kinder nicht mit den festen Bedienelementen spielen. Halten Sie die Fernbedienungen von Kindern fern.
- Vermeiden Sie Arbeiten in der Nähe der Scharniere oder der beweglichen Bauteile.
- Halten Sie die Bewegung der Tür nicht auf und versuchen Sie nicht, die Tür von Hand zu öffnen, wenn der Trieb nicht mit dem entsprechenden Entsperrhebel entsperrt worden ist.
- Halten Sie sich während der Bewegung aus dem Aktionsradius der Tür oder des motorisierten Tors fern.
- Halten Sie die Funkfernbedienung oder sonstige Steuerungsvorrichtungen von Kindern fern, um unbeabsichtigte Betätigungen der Automatisierung zu vermeiden.
- Die Aktivierung der manuellen Entsperrung könnte bei mechanischen Defekten oder Ungleichgewichtssituationen zu unkontrollierten Bewegungen der Tür führen.
- Bei Rolladenautomatisierungen: Überwachen Sie den Rolladen während der Bewegung und halten Sie Personen fern, bis er vollständig geschlossen ist. Gehen Sie bei der Betätigung der eventuellen Entsperrung mit Vorsicht vor, da der offene Rolladen bei Brüchen oder Abnutzungen herunterfallen könnte.
- Das Brechen oder die Abnutzung der mechanischen Organe der Tür (geführter Teil) wie zum Beispiel Kabel, Federn, Aufhängungen, Führungen usw. könnte zu Gefahren führen. Lassen Sie die Anlage in regelmäßigen Abständen von qualifiziertem Fachpersonal (professioneller Installateur) unter Beachtung der Angaben des Installateurs oder des Herstellers der Tür überprüfen.
- Unterbrechen Sie vor allen externen Reinigungsarbeiten die Stromversorgung.
- Halten Sie die Linsen der Fotozellen und die Anzeigevorrichtungen sauber. Stellen Sie sicher, dass die Sicherheitsvorrichtungen nicht durch Zweige oder Sträucher beeinträchtigt werden.
- Benutzen Sie die Automatisierung nicht, falls sie Reparatureingriffe erforderlich macht. Unterbrechen Sie bei Beschädigungen oder Funktionsstörungen die Stromversorgung der Automatisierung, unternehmen Sie keine Reparaturversuche oder direkte Eingriffe und wenden Sie sich für die erforderliche Reparatur oder Wartung an qualifiziertes Fachpersonal (professioneller Installateur). Aktivieren Sie für den Zugang die Notfallentsperrung (falls vorhanden).
- Wenden Sie sich für alle im vorliegenden Handbuch nicht vorgesehenen direkten Eingriffe an der Automatisierung oder der Anlage an qualifiziertes Fachpersonal (professioneller Installateur).
- Lassen Sie die Unversehrtheit und den ordnungsgemäßen Betrieb der Automatisierung sowie insbesondere der Sicherheitsvorrichtungen zumindest einmal jährlich von qualifiziertem Fachpersonal (professioneller Installateur) überprüfen.
- Die Installations-, Wartungs- und Reparatureingriffe müssen dokumentiert werden

und die Dokumentation muss dem Benutzer zur Verfügung gehalten werden.  
-Die Nichtbeachtung dieser Anweisung kann zu Gefahrensituationen führen.

**Alles, was im Installationshandbuch nicht ausdrücklich vorgesehen ist, ist untersagt. Der ordnungsgemäße Betrieb des Triebs kann nur garantiert werden, wenn alle angegebenen Daten eingehalten werden. Die Firma haftet nicht für Schäden, die auf die Nichtbeachtung der Hinweise im vorliegenden Handbuch zurückzuführen sind.**

**Unter Beibehaltung der wesentlichen Eigenschaften des Produktes kann die Firma jederzeit und ohne Verpflichtung zur Aktualisierung des vorliegenden Handbuchs Änderungen zur technischen, konstruktiven oder handelsrechtlichen Verbesserung vornehmen.**

## ADVERTENCIAS PARA EL USUARIO (E)

**¡ATENCIÓN! Instrucciones de seguridad importantes. Leer y seguir con atención las Advertencias y las Instrucciones que acompañan el producto, ya que el uso inapropiado puede causar daños a personas, animales o cosas. Guardar las instrucciones para futuras consultas y transmitir las a eventuales reemplazantes en el uso de la instalación.**

**Este producto se deberá utilizar únicamente para el uso para el cual ha sido expresamente instalado. Cualquier otro uso se considerará inadecuado y por lo tanto peligroso. El fabricante no se responsabiliza por posibles daños causados debido a usos inapropiados, erróneos e irrazonables.**

### SEGURIDAD GENERAL

Le agradecemos por haber elegido este producto, en la Empresa estamos seguros que obtendrán las prestaciones necesarias para su uso.

Este producto responde a las normas reconocidas de la técnica y de las disposiciones inherentes a la seguridad siempre que haya sido correctamente instalado por personal cualificado y experto (instalador profesional).

La automatización, si se instala y utiliza de manera correcta, cumple con los estándares de seguridad para el uso. Sin embargo es conveniente respetar algunas reglas de comportamiento para evitar inconvenientes accidentales:

- Mantener a niños, personas y cosas fuera del radio de acción de la automatización, especialmente durante su movimiento.
- No permitir que los niños jueguen o permanezcan en el radio de acción de la automatización.
- Esta automatización no está destinada para ser utilizada por niños o por personas con capacidades mentales, físicas y sensoriales reducidas, o personas que no cuenten con conocimientos adecuados, salvo que sean supervisadas o hayan recibido instrucciones de uso del equipo por parte de una persona responsable de su seguridad.
- Los niños deben ser vigilados para cerciorarse que no jueguen con el equipo. No permitir que los niños jueguen con los controles fijos. Mantener los mandos a distancia alejados de los niños.
- Evitar operar cerca de las bisagras o de los órganos mecánicos en movimiento.
- No obstaculizar el movimiento de la hoja y no intentar abrir manualmente la puerta si no se ha desbloqueado el accionador con el botón de desbloqueo específico.
- No ingresar al radio de acción de la puerta o cancela motorizadas durante el movimiento de las mismas.
- No dejar radiomandos u otros dispositivos de mando al alcance de niños, para evitar accionamientos involuntarios.
- La activación del desbloqueo manual podría causar movimientos incontrolados de la puerta en caso de averías mecánicas o condiciones de desequilibrio.
- En caso de automatizaciones para persianas enrollables: vigilar la persiana en movimiento y mantener alejadas a las personas hasta que esté completamente cerrada. Tener precaución cuando se acciona el desbloqueo, si estuviera presente, puesto que una persiana enrollable abierta podría caer rápidamente en caso de desgaste o roturas.
- La rotura o el desgaste de órganos mecánicos de la puerta (parte guiada), como por ejemplo cables, muelles, soportes, goznes, guías, etc. podría generar peligros. Hacer controlar periódicamente la instalación por personal cualificado y experto (instalador profesional), según lo indicado por el instalador o por el fabricante de la puerta.
- Para cualquier operación de limpieza exterior, interrumpir la alimentación de red.
- Mantener limpias las ópticas de las fotocélulas y los dispositivos de señalización luminosa. Controlar que ramas y arbustos no obstaculicen los dispositivos de seguridad.
- No utilizar la automatización si necesita intervenciones de reparación. En caso de avería o de defecto de funcionamiento de la automatización, interrumpir la alimentación de red en la automatización, abstenerse de cualquier intento de reparación o intervención directa y recurrir sólo a personal cualificado y experto (instalador profesional) para la necesaria reparación y mantenimiento. Para permitir el acceso, activar el desbloqueo de emergencia (si estuviera presente).
- Para cualquier intervención directa en la automatización o en la instalación no prevista por el presente manual, recurrir a personal cualificado y experto (instalador profesional).
- Al menos una vez al año hacer controlar la integridad y el correcto funcionamiento de la automatización por personal cualificado y experto (instalador profesional), en particular de todos los dispositivos de seguridad.
- Las intervenciones de instalación, mantenimiento y reparación deben ser registradas y la documentación correspondiente se debe mantener a disposición del usuario.
- El incumplimiento de lo antes indicado puede provocar situaciones de peligro.

**BFT S.P.A.**

Via Lago di Vico 44, 36015 Schio (Vi) - **Italy**  
tel. +39 0445 69 65 11 / fax. +39 0445 69 65 22  
www.bft.it / e-mail: info@bft.it

**AUTOMATISMES BFT FRANCE**

13 Bd. E. Michelet, 69008 Lyon - **France**  
tel. +33 (0)4 78 76 09 88 - fax +33 (0)4 78 76 92 23  
e-mail: contacts@automatismes-bft-france.fr

**BFT Torantriebssysteme GmbH**

Faber-Castell-Straße 29  
D - 90522 Oberasbach - **Germany**  
tel. +49 (0)911 766 00 90 - fax +49 (0)911 766 00 99  
e-mail: service@bft-torantriebe.de

**BFT Automation UK Ltd**

Unit 8E, Newby Road  
Industrial Estate Hazel Grove, Stockport,  
Cheshire, SK7 5DA - **UK**  
tel. +44 (0) 161 4560456 - fax +44 (0) 161 4569090  
e-mail: info@bftautomation.co.uk

**BFT BENELUX SA**

Parc Industriel 1, Rue du commerce 12  
1400 Nivelles - **Belgium**  
tel. +32 (0)67 55 02 00 - fax +32 (0)67 55 02 01  
e-mail: info@bftbenelux.be

**BFT-ADRIA d.o.o.**

Obrovac 39  
51218 Dražice (Rijeka)  
Hrvatska - **Croatia**  
tel. +385 (0)51 502 640 - fax +385 (0)51 502 644  
e-mail: info@bft.hr

**BFT Polska Sp. z o.o.**

ul. Kolacińska 35  
03-171 Warszawa - **Poland**  
tel. +48 22 814 12 22 - fax +48 22 814 39 18  
e-mail: biuro@bft.com.pl

**BFT USA BFT U.S., Inc.**

6100 Broken Sound Pkwy, N.W., Suite 14  
Boca Raton, FL 33487 - **U.S.A.**  
T: +1 561.995.8155 - F: +1 561.995.8160  
TOLL FREE 1.877.995.8155 - info.bft@bft-usa.com

**BFT GROUP ITALIBERICA DE AUTOMATISMOS S.L.**

**Pol. Palou Nord,**  
Sector F - C/Cami - Can Basa nº 6-8 08401 Granollers -  
**(Barcelona) - Spain**  
tel. +34 938 61 48 28 - fax +34 938 70 03 94  
e-mail: bftbcn@bftautomatismos.com

**Pl. Comendador - C/**  
informática, Nave 22 - 19200 Azuqueca de henares  
**(Guadalajara) - Spain**  
tel. +34 949 26 32 00 - fax +34 949 26 24 51  
e-mail: administracion@bftautomatismos.com

**BFT SA-COMERCIO DE AUTOMATISMOS E MATERIAL DE SEGURANÇA**  
Urbanizaçao da Pedrulha Lote 9 - Apartado 8123,  
3020-305 COIMBRA - **PORTUGAL**  
tel. +351 239 082 790 - fax +351 239 082 799  
e-mail: geral@bftportugal.com